

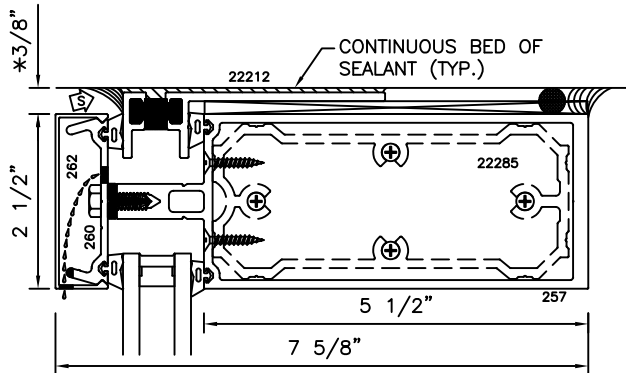

2-1/2" X 7-5/8" (5-1/2" B. M.) 250 C.W. EXTERIOR GLAZED CURTAIN WALL STANDARD / OPTIONAL DETAILS

* MINIMUM RECOMMENDED FOR THERMAL ISOLATION.
INCREASE AS REQUIRED TO COMPLY WITH SEALANT
MANUFACTURERS' INSTRUCTIONS

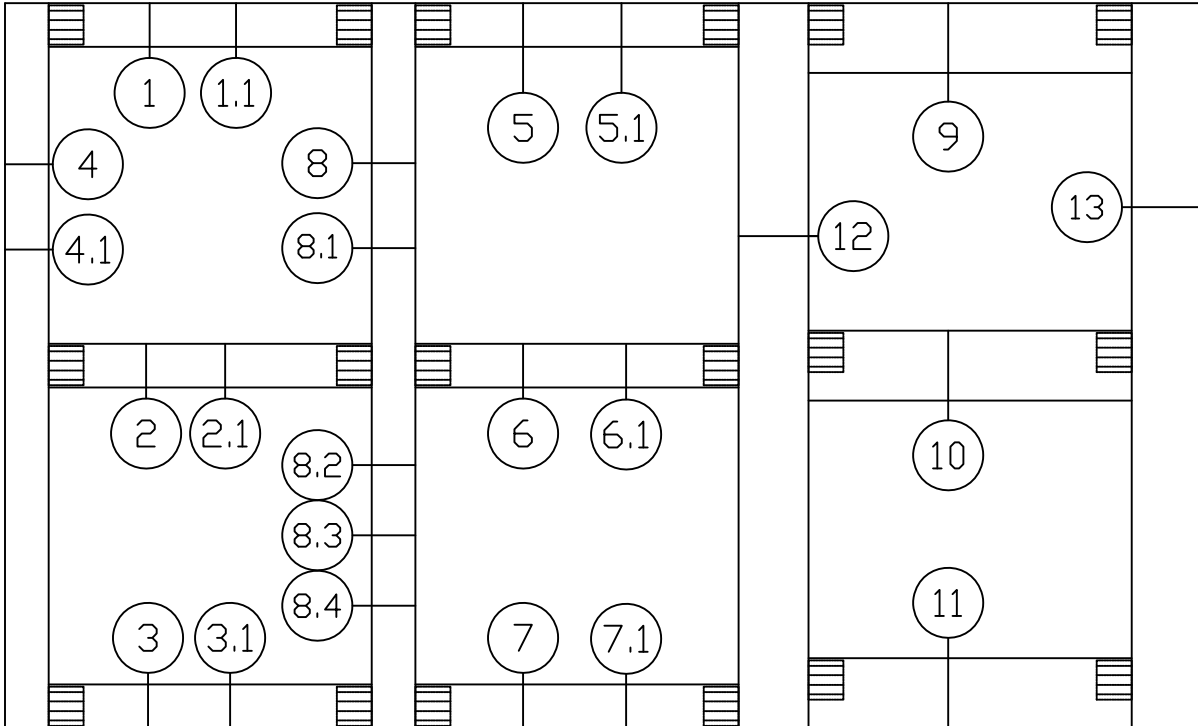

1

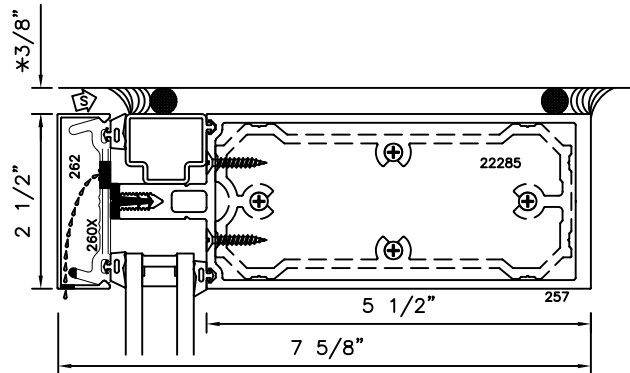

1.1

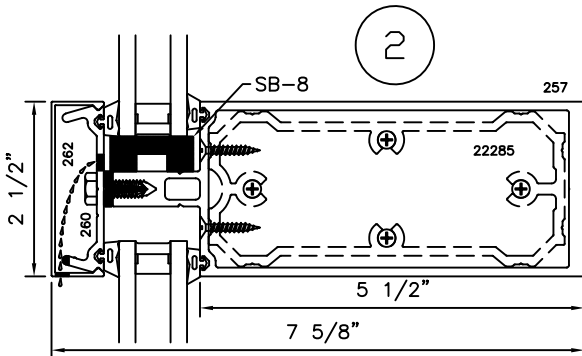

2

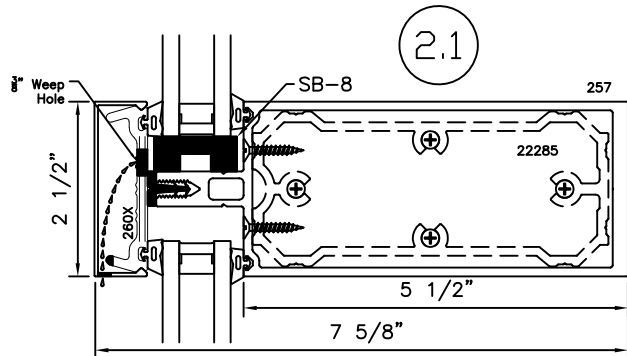

2.1



2-1/2" X 7-5/8" (5 1/2" B. M.) 250 C.W. EXTERIOR GLAZED CURTAIN WALL STANDARD / OPTIONAL DETAILS

* MINIMUM RECOMMENDED FOR THERMAL ISOLATION.
INCREASE AS REQUIRED TO COMPLY WITH SEALANT
MANUFACTURERS' INSTRUCTIONS

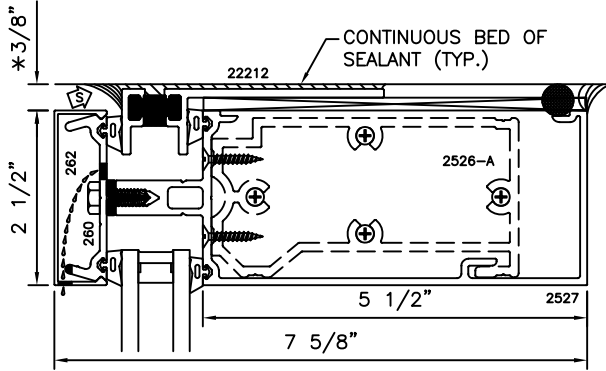

5

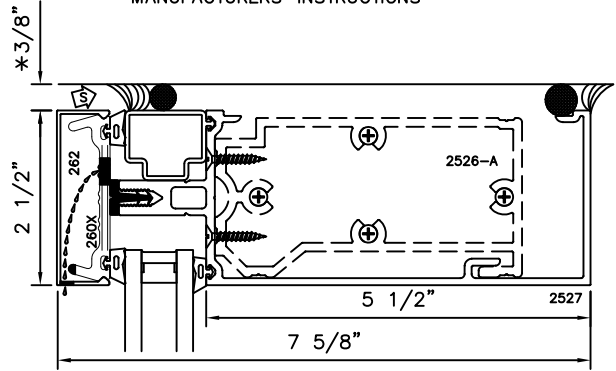

5.1

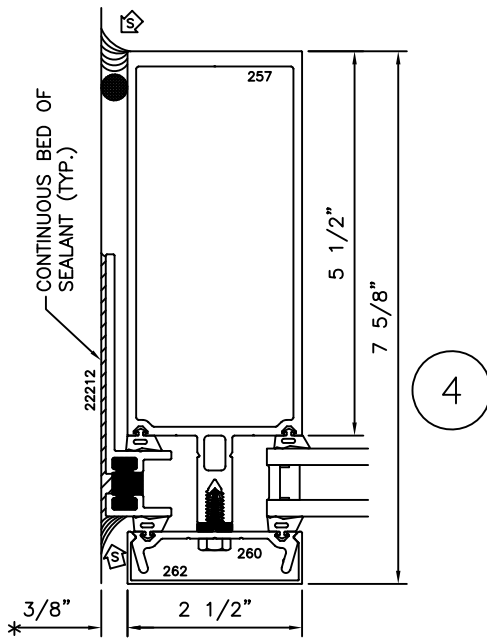

4

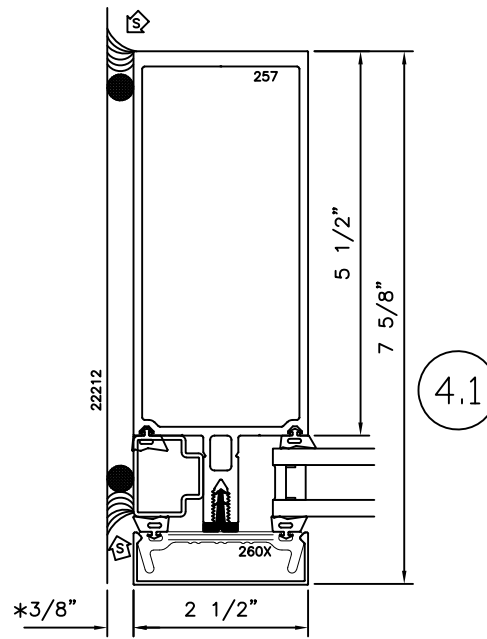

4.1

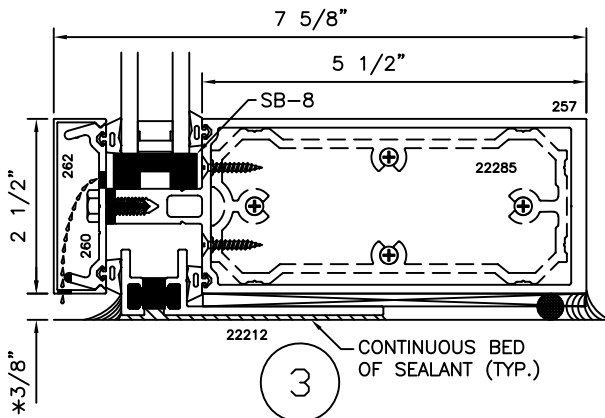

3

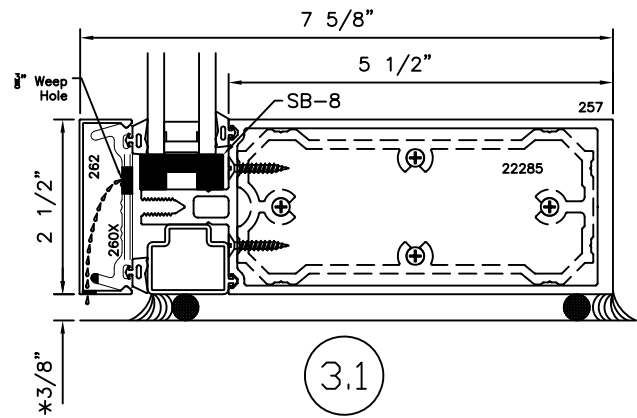

3.1



2-1/2" X 7-5/8" (5 1/2" B. M.) 250 C.W. EXTERIOR GLAZED CURTAIN WALL STANDARD / OPTIONAL DETAILS

* MINIMUM RECOMMENDED FOR THERMAL ISOLATION.
INCREASE AS REQUIRED TO COMPLY WITH SEALANT
MANUFACTURERS' INSTRUCTIONS

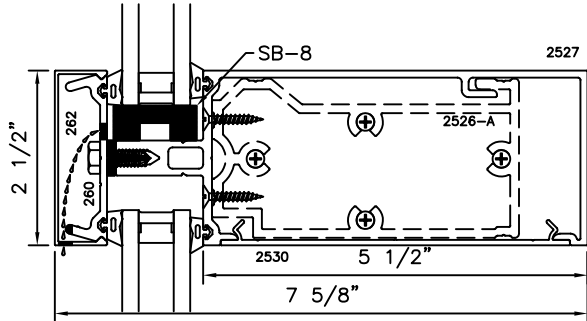

6

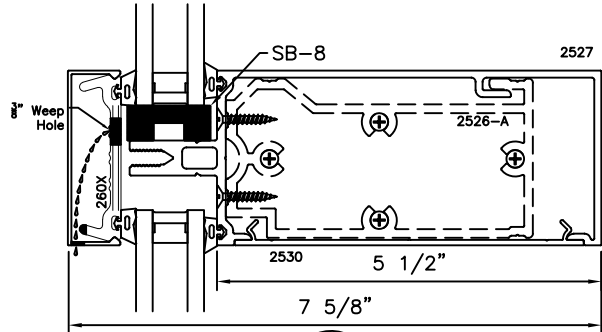

6.1

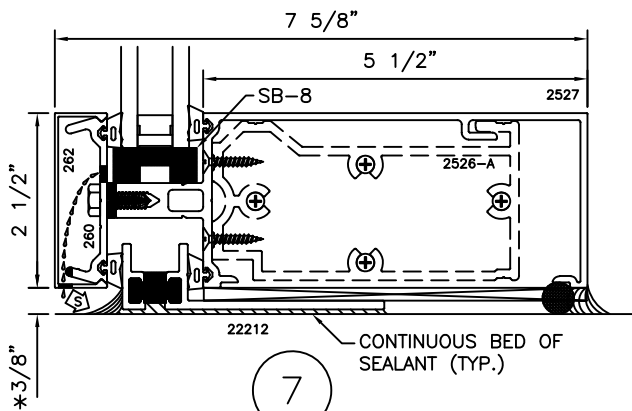

7

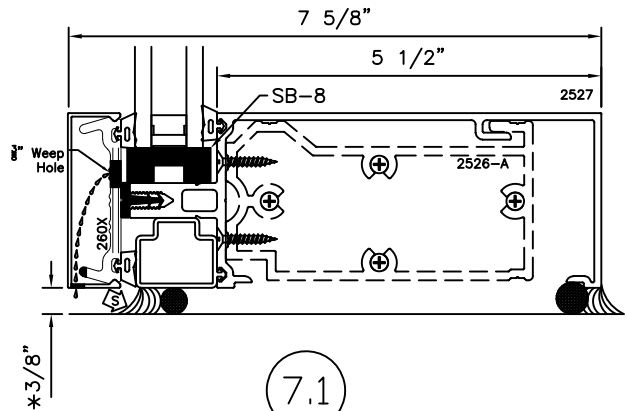

7.1

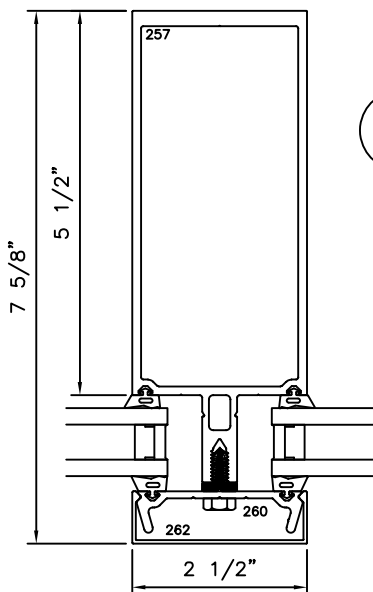

8

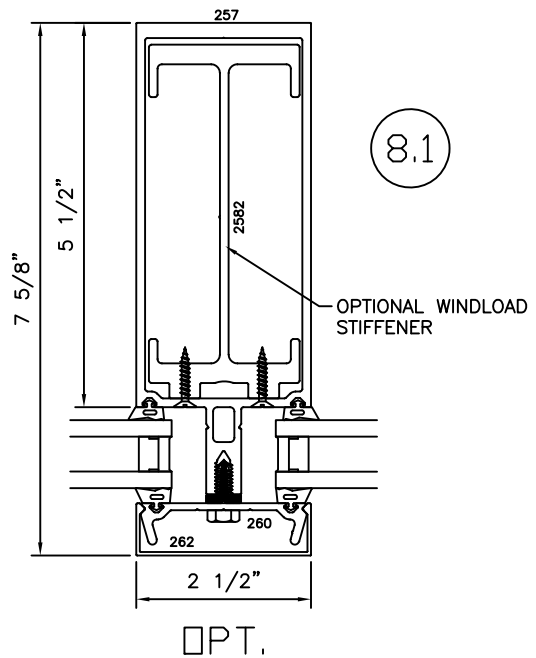

8.1



2-1/2" X 7-5/8" (5 1/2" B. M.)
250 C.W. EXTERIOR GLAZED CURTAIN WALL
 STANDARD / OPTIONAL DETAILS

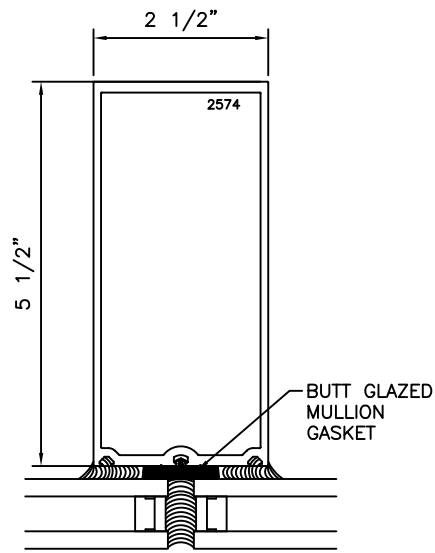

OPT.
 8.2

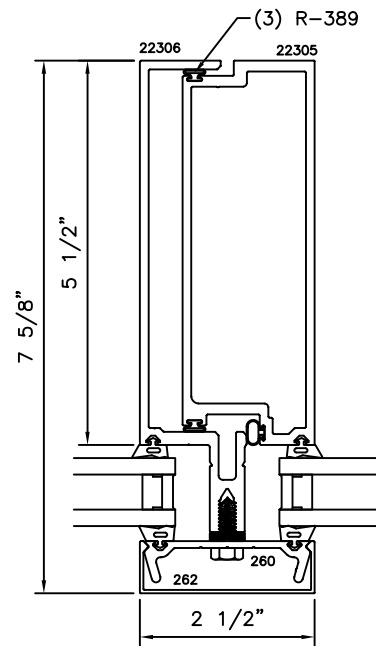

OPT.
 8.3

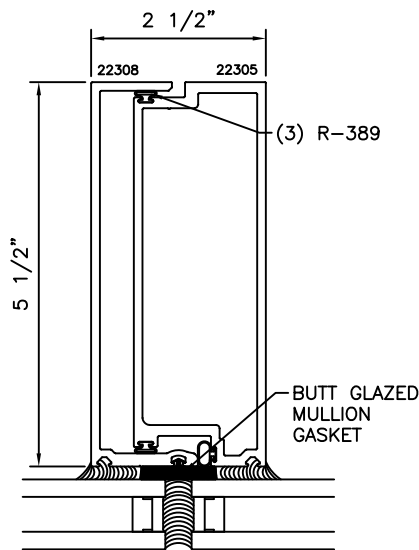

OPT.
 8.4

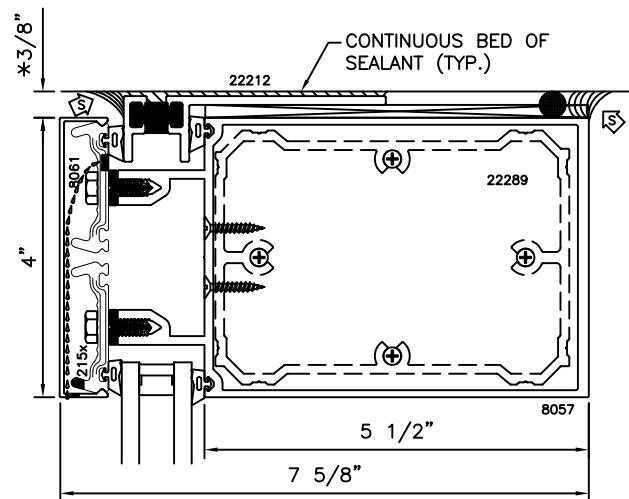

9



2-1/2" X 7-5/8" (5 1/2" B. M.) 250 C.W. EXTERIOR GLAZED CURTAIN WALL STANDARD / OPTIONAL DETAILS

* MINIMUM RECOMMENDED FOR THERMAL ISOLATION.
INCREASE AS REQUIRED TO COMPLY WITH SEALANT
MANUFACTURERS' INSTRUCTIONS

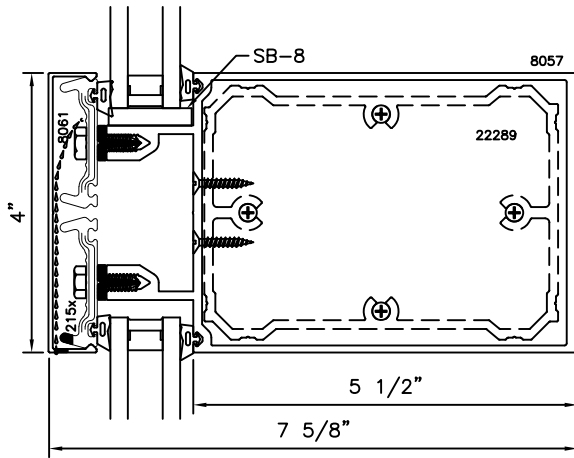

10

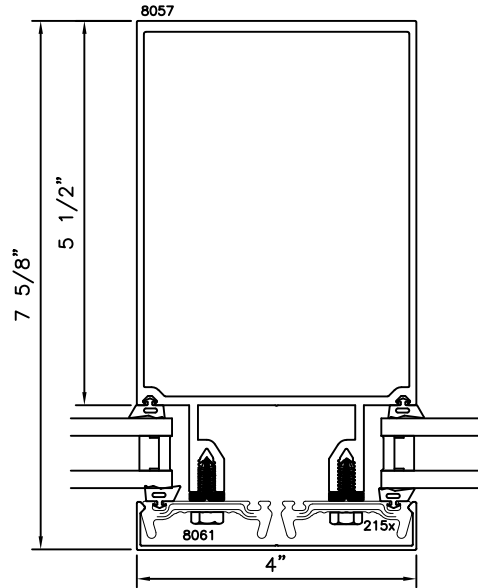

12

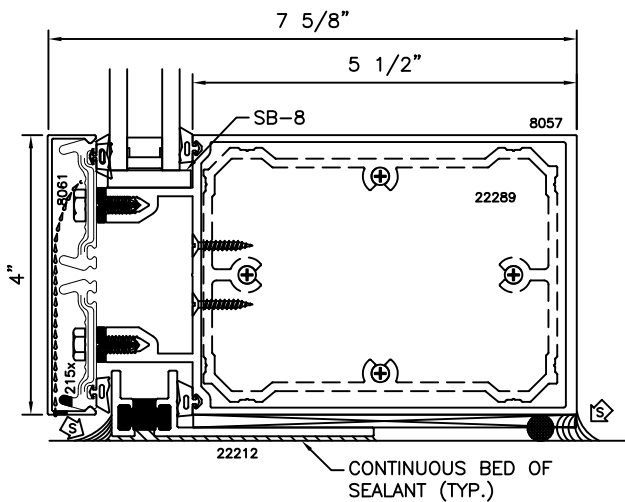

11

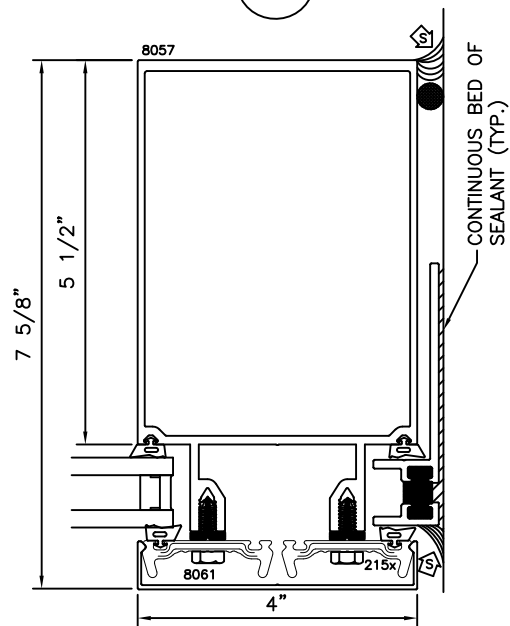

13