

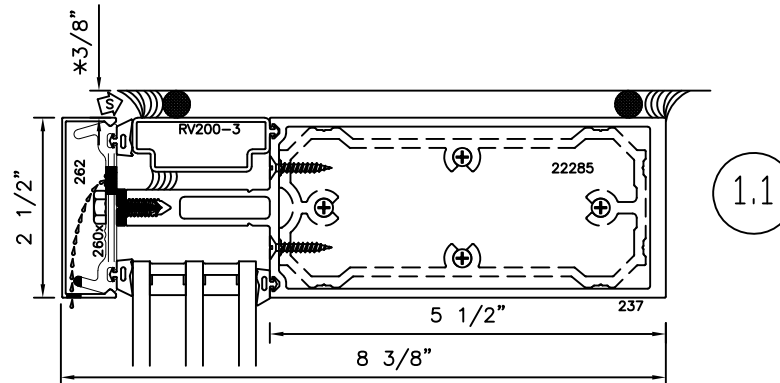

2-1/2" X 8 3/8" (5-1/2" B. M.) 250 C.W. EXTERIOR GLAZED CURTAIN WALL TRIPLE PANE DETAILS

Nominal 1-3/4" Glazing Details

* MINIMUM RECOMMENDED FOR THERMAL ISOLATION.
INCREASE AS REQUIRED TO COMPLY WITH SEALANT
MANUFACTURERS' INSTRUCTIONS

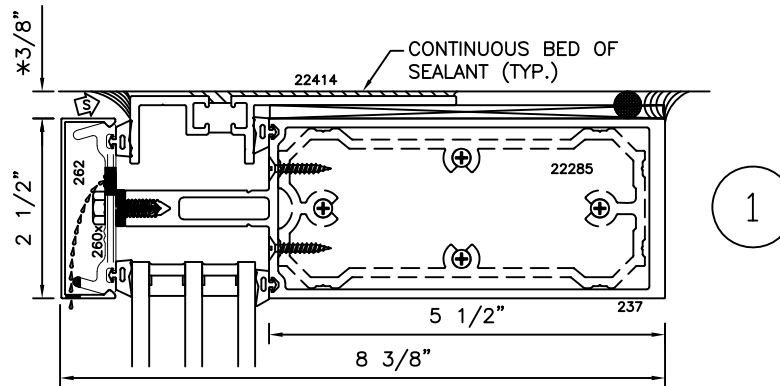
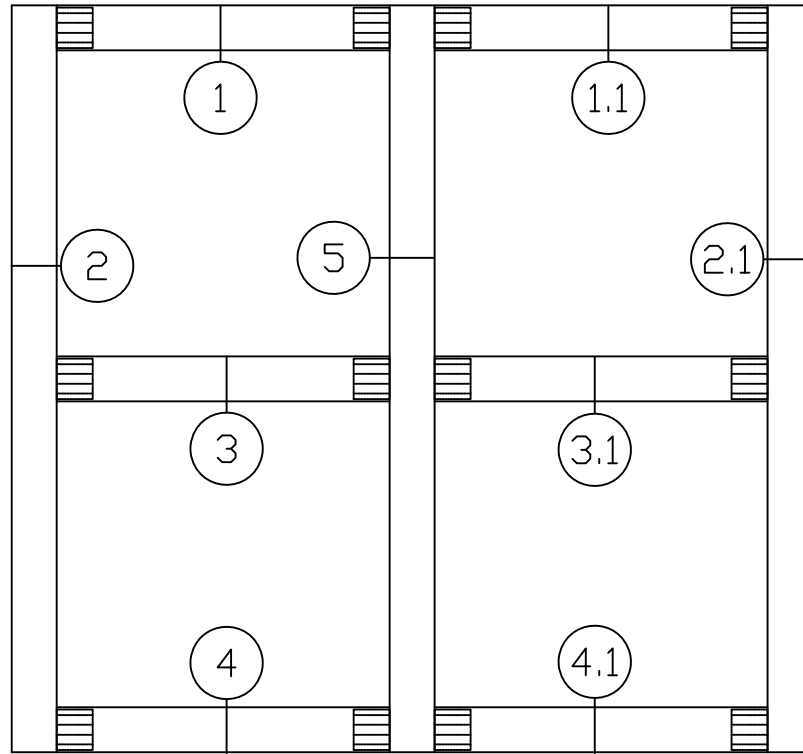



2-1/2" X 8 3/8" (5-1/2" B. M.) 250 C.W. EXTERIOR GLAZED CURTAIN WALL TRIPLE PANE DETAILS

Nominal 1-3/4" Glazing Details

* MINIMUM RECOMMENDED FOR THERMAL ISOLATION.
INCREASE AS REQUIRED TO COMPLY WITH SEALANT
MANUFACTURERS' INSTRUCTIONS

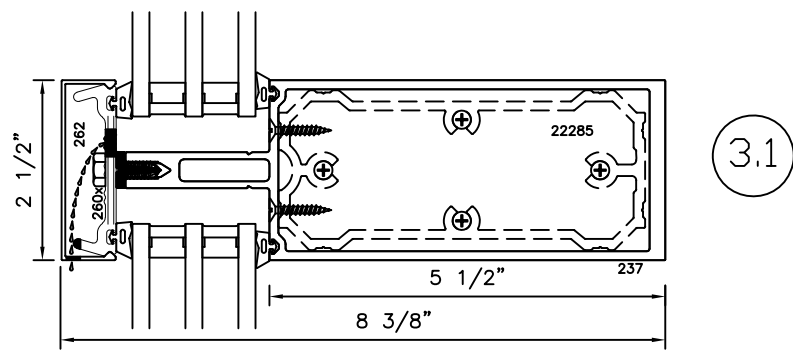
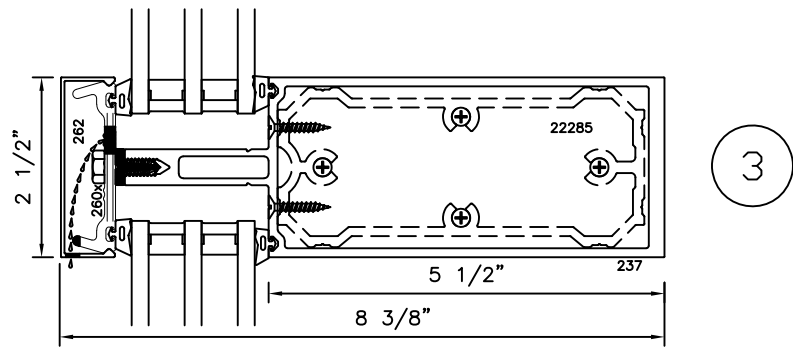
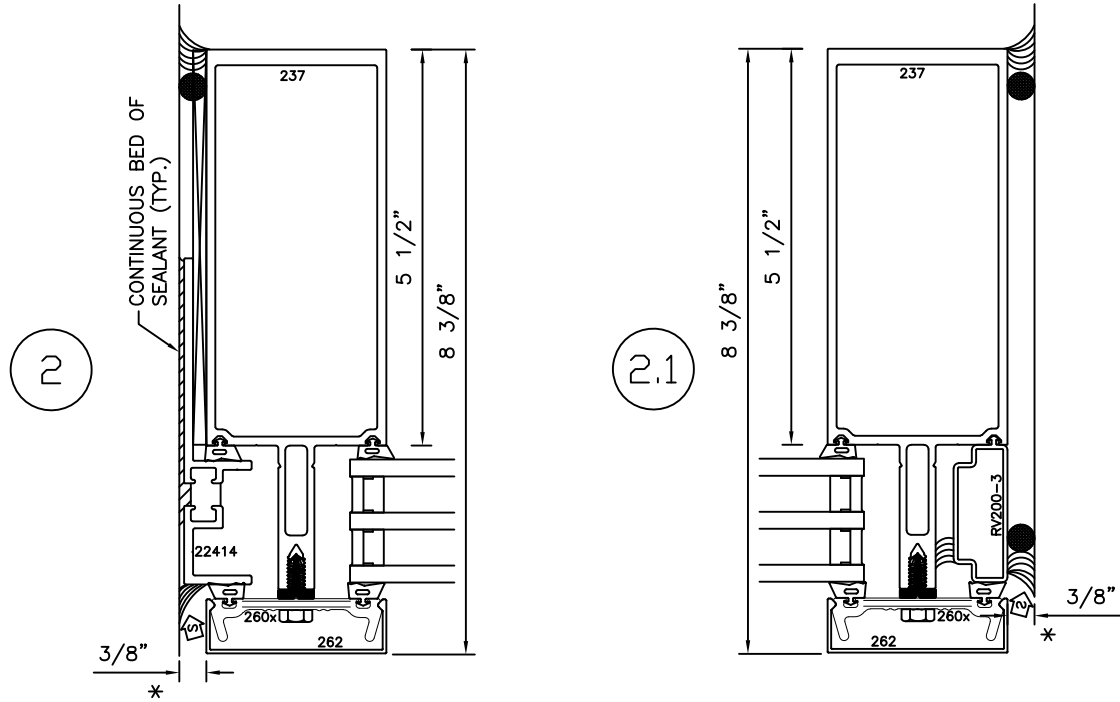



2-1/2" X 8 3/8" (5-1/2" B. M.) 250 C.W. EXTERIOR GLAZED CURTAIN WALL TRIPLE PANE DETAILS

Nominal 1-3/4" Glazing Details

* MINIMUM RECOMMENDED FOR THERMAL ISOLATION.
INCREASE AS REQUIRED TO COMPLY WITH SEALANT
MANUFACTURERS' INSTRUCTIONS

