

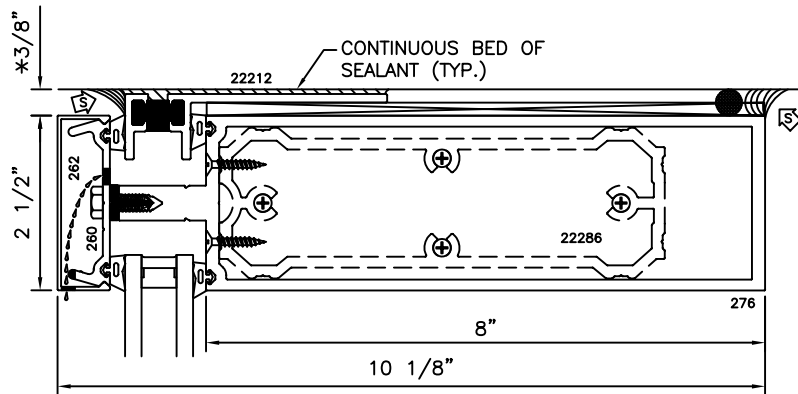

2-1/2" X 10-1/8" (8" B. M.) 250 C.W. EXTERIOR GLAZED CURTAIN WALL STANDARD / OPTIONAL DETAILS

* MINIMUM RECOMMENDED FOR THERMAL ISOLATION.
INCREASE AS REQUIRED TO COMPLY WITH SEALANT
MANUFACTURERS' INSTRUCTIONS

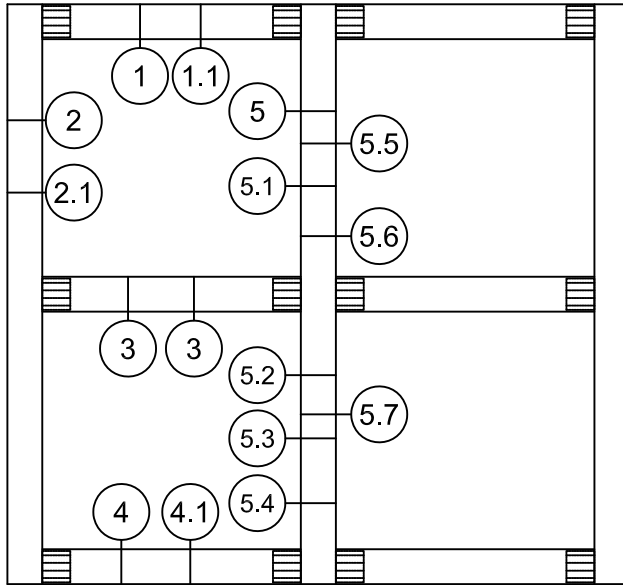

1

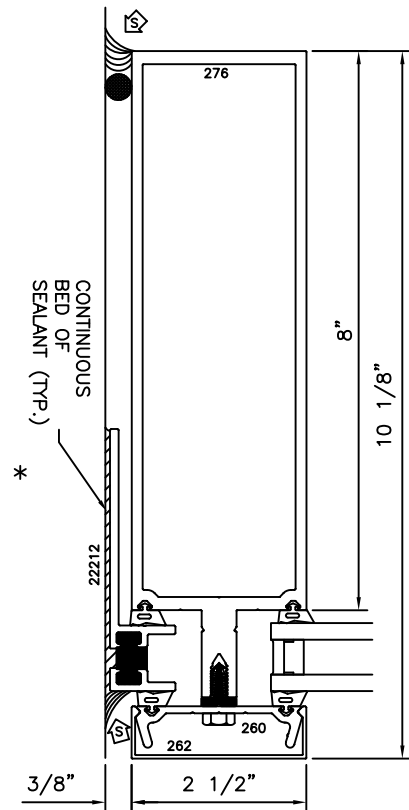

2

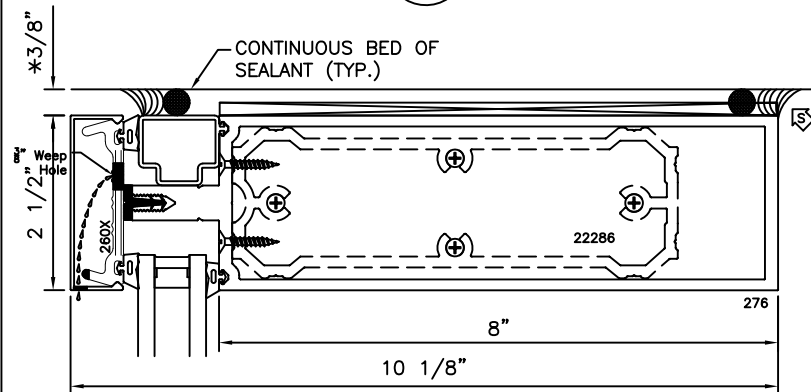

1.1



2-1/2" X 10-1/8" (8" B. M.) 250 C.W. EXTERIOR GLAZED CURTAIN WALL STANDARD / OPTIONAL DETAILS

* MINIMUM RECOMMENDED FOR THERMAL ISOLATION. INCREASE AS REQUIRED TO COMPLY WITH SEALANT MANUFACTURERS' INSTRUCTIONS

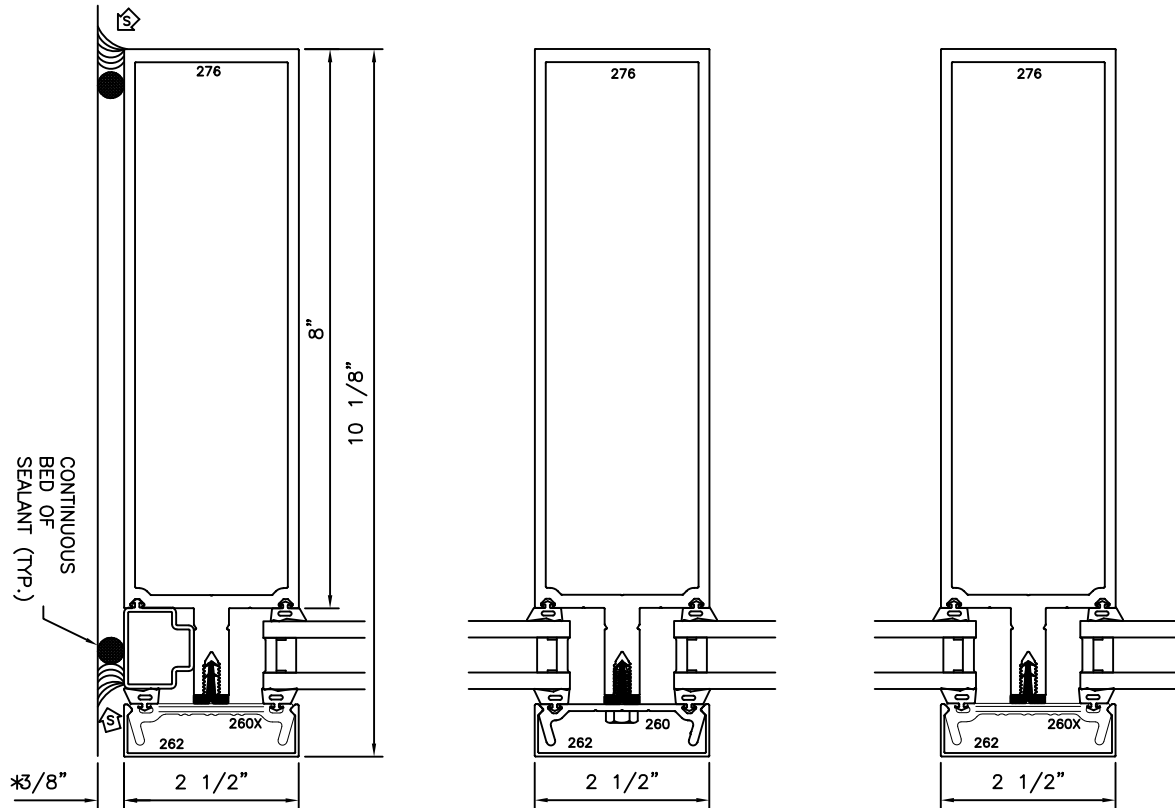

2.1

5

5.1

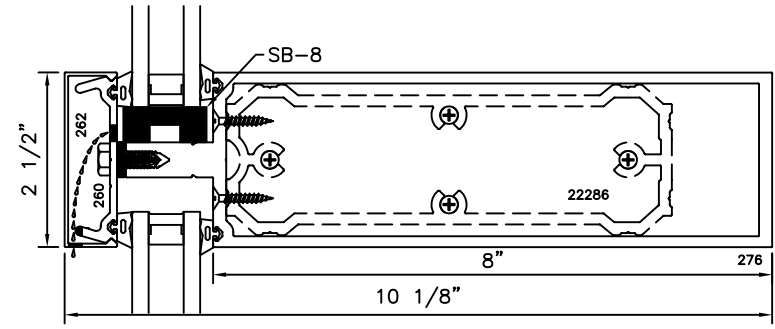

3

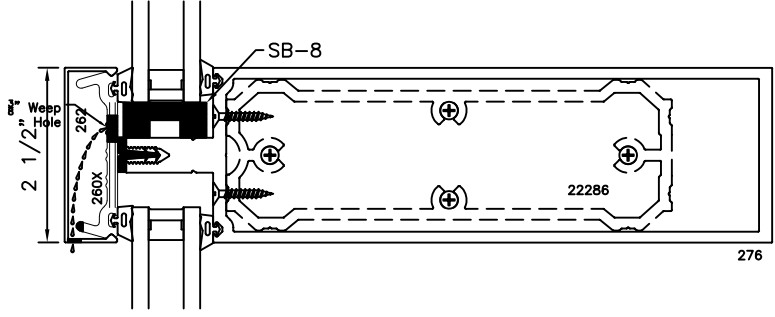

3.1



2-1/2" X 10-1/8" (8" B. M.)
250 C.W. EXTERIOR GLAZED CURTAIN WALL
 STANDARD / OPTIONAL DETAILS

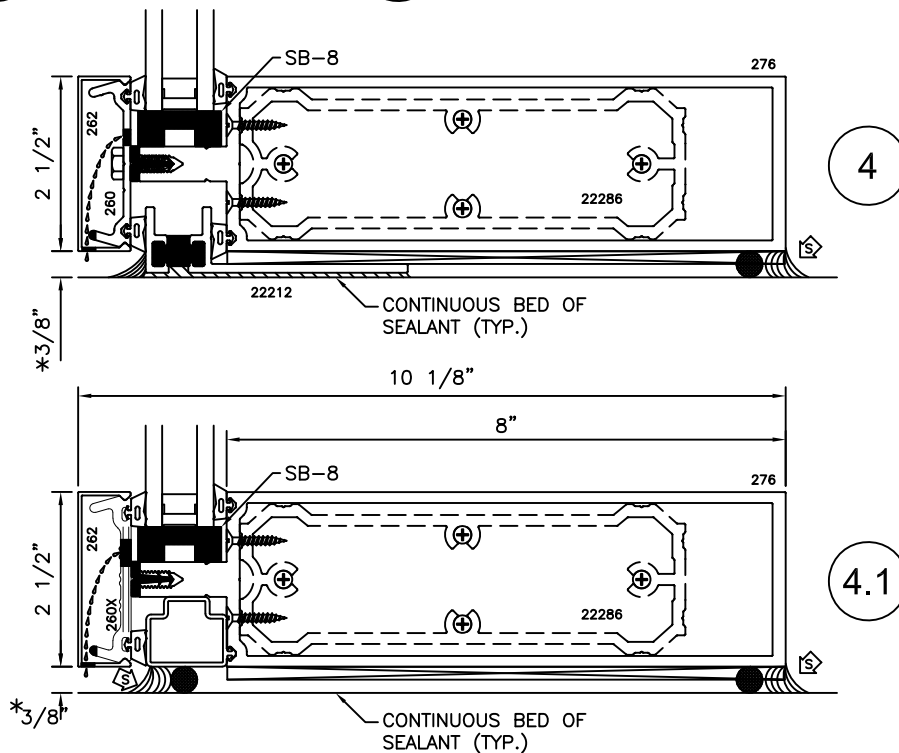
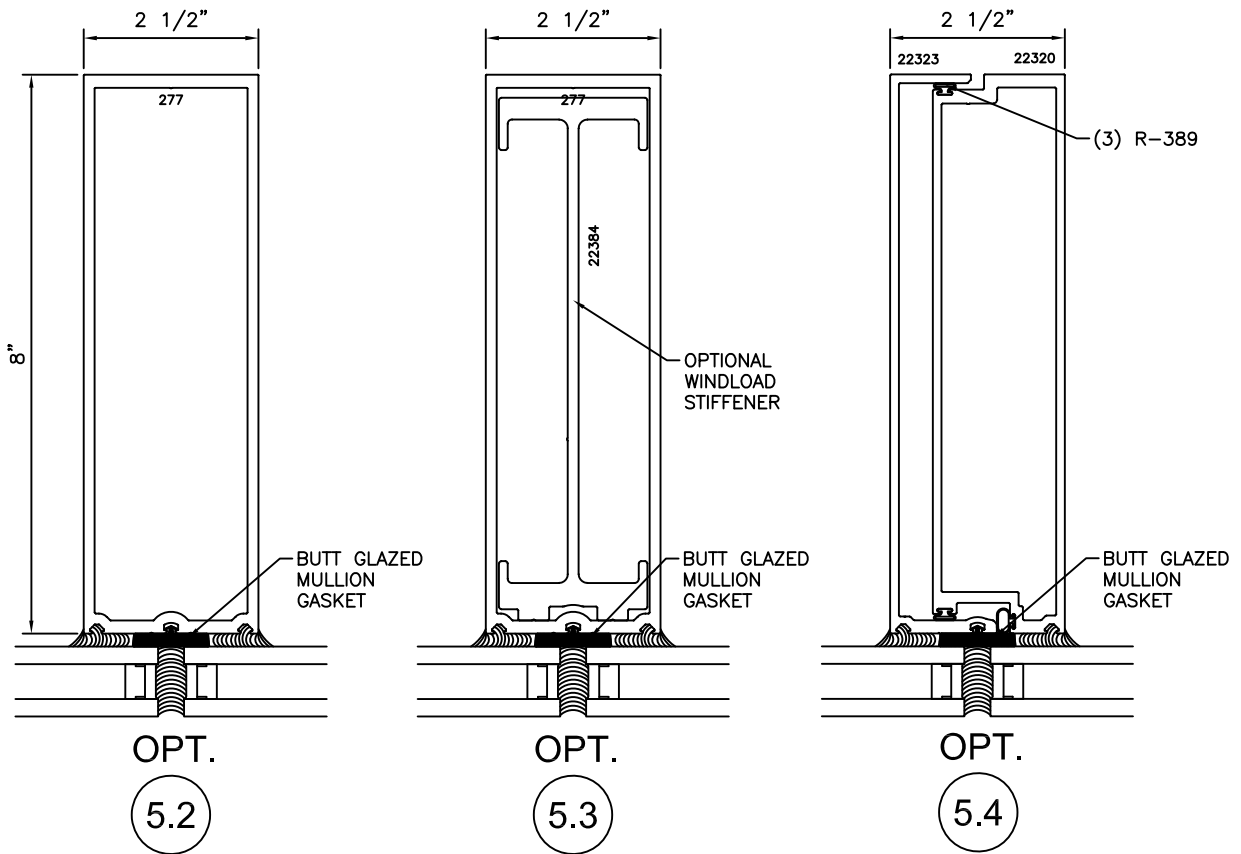



2-1/2" X 10-1/8" (8" B. M.)
250 C.W. EXTERIOR GLAZED CURTAIN WALL
STANDARD / OPTIONAL DETAILS

