



MANKO

WINDOW SYSTEMS INC.

2450xpt Series Accessory Details

Table of Contents

Glazing Options.....	1
Receptors.....	2
Sub-Sills.....	3



MANKO

2450CGXPT

4 1/2" DOUBLE THERMAL STOREFRONT OPT. GLAZING CONFIGURATION

* MINIMUM RECOMMENDED FOR THERMAL ISOLATION. INCREASE AS REQUIRED TO COMPLY WITH SEALANT MANUFACTURERS' INSTRUCTIONS

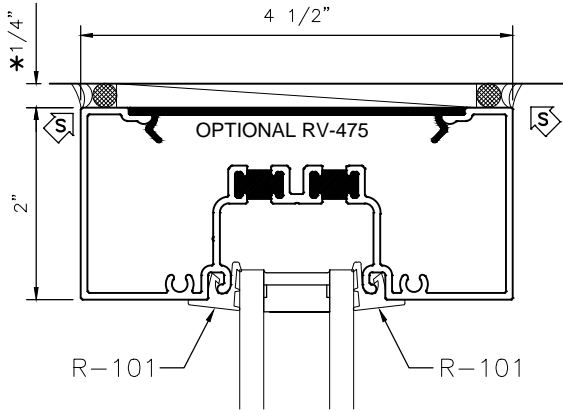

1 1/8" GLAZING

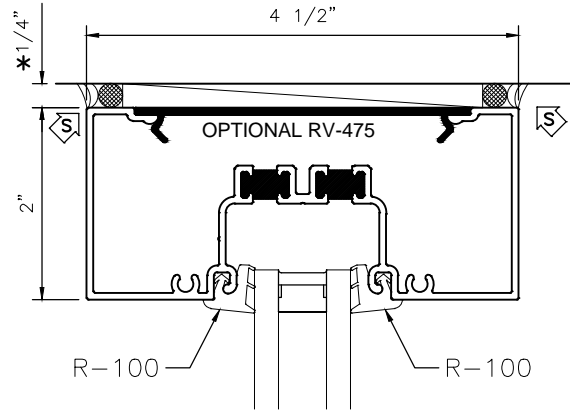

1" GLAZING

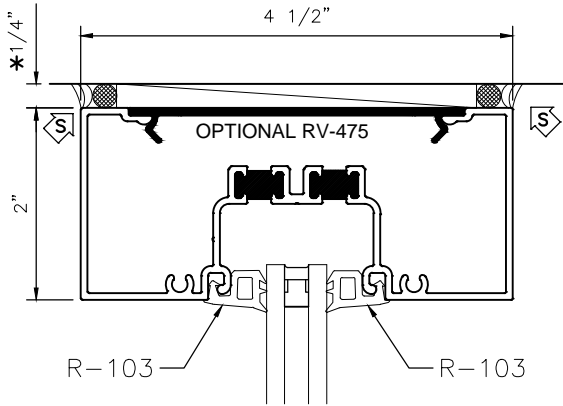

5/8" GLAZING

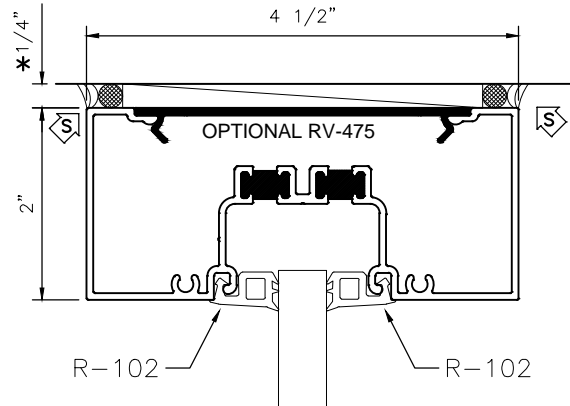

1/2" GLAZING

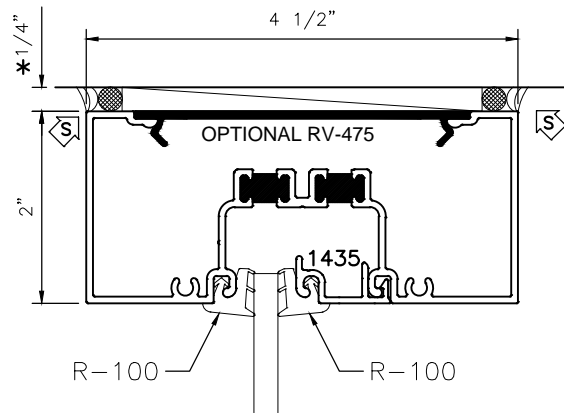

1/4" GLAZING

PART # 6451 SHOWN. SIMILAR THROUGHOUT SERIES.



MANKO

2450CGXPT

4 1/2" DOUBLE THERMAL BROKEN STOREFRONT RECEPTOR DETAILS

* MINIMUM RECOMMENDED FOR THERMAL ISOLATION.
INCREASE AS REQUIRED TO COMPLY WITH SEALANT
MANUFACTURERS' INSTRUCTIONS

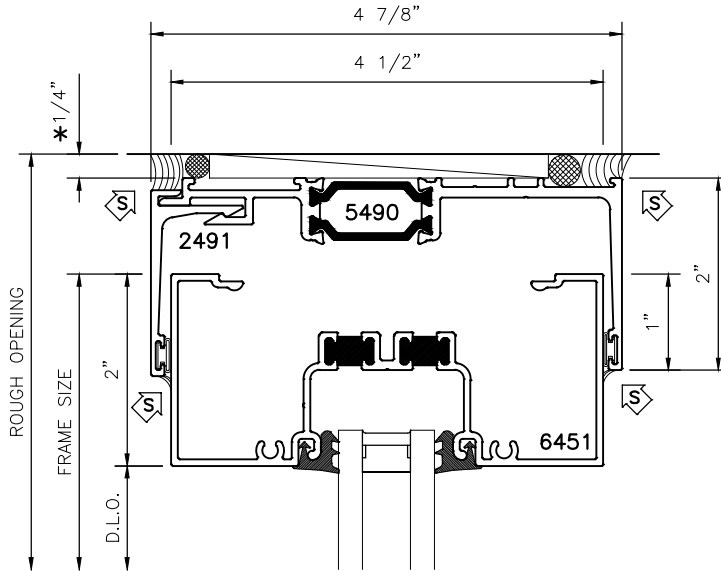

HEAD

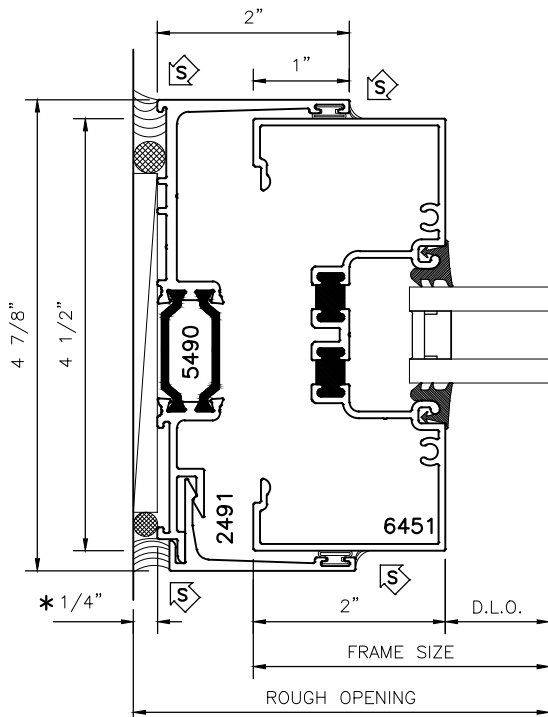

LEFT JAMB

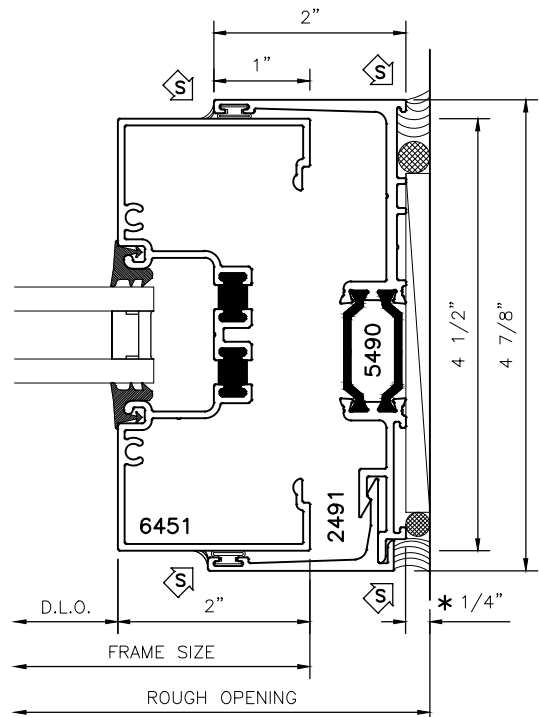

RIGHT JAMB



2450CGXPT

4 1/2" DOUBLE THERMALLY BROKEN STOREFRONT SUB-SILL DETAILS

*MINIMUM RECOMMENDED FOR THERMAL ISOLATION.
INCREASE AS REQUIRED TO COMPLY WITH SEALANT
MANUFACTURERS' INSTRUCTIONS

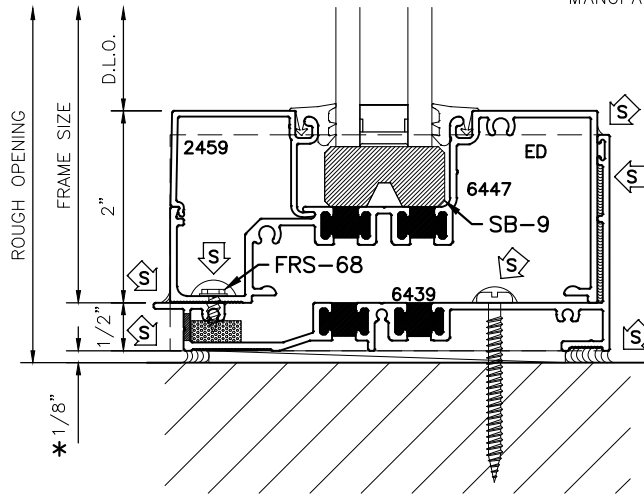

CONCEALED FASTENER.

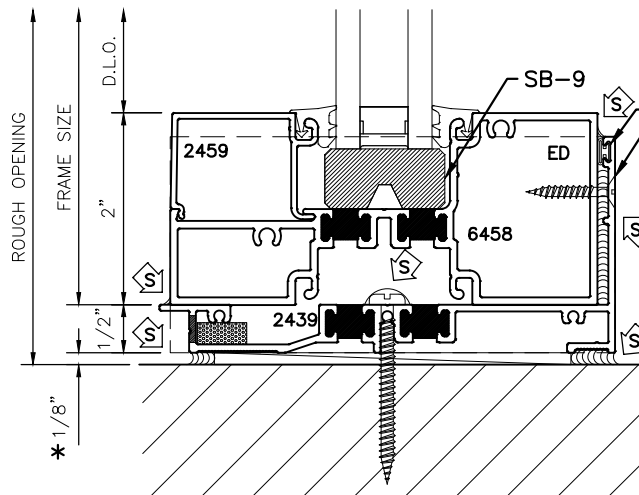

EXPOSED FASTENER.

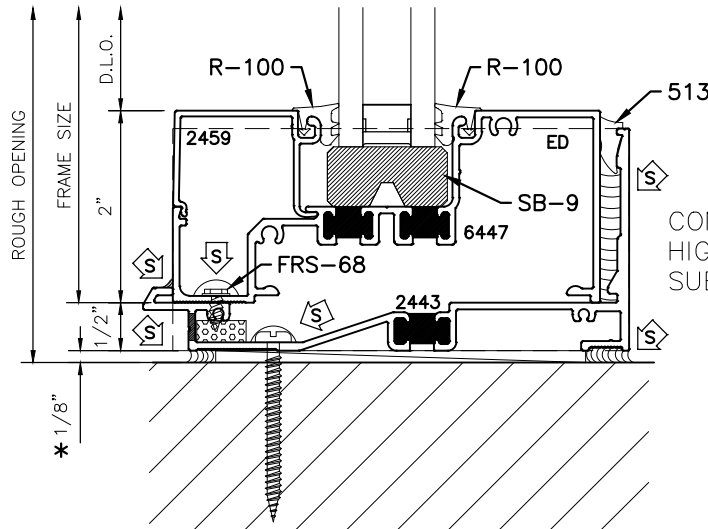

CONCEALED FASTENER.
HIGH PERFORMANCE
SUB-SILL