



MANKO

WINDOW SYSTEMS INC.

250-250x Series 4" Back Member Details

Table of Contents

Standard & Optional Details.....	1-5
F&T Details.....	6-7
Corner Details.....	8



2-1/2" X 6-1/8" (4" B. M.) 250 C.W. EXTERIOR GLAZED CURTAIN WALL STANDARD / OPTIONAL DETAILS

* MINIMUM RECOMMENDED FOR THERMAL ISOLATION.
INCREASE AS REQUIRED TO COMPLY WITH SEALANT
MANUFACTURERS' INSTRUCTIONS

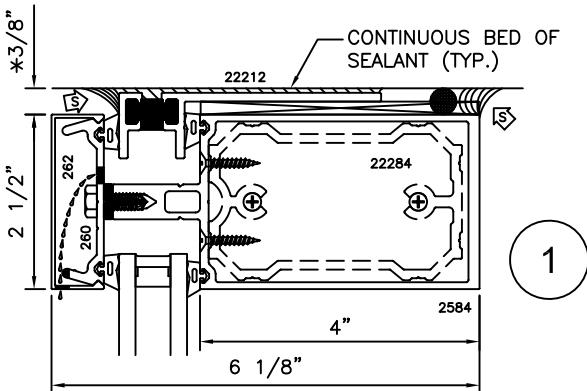
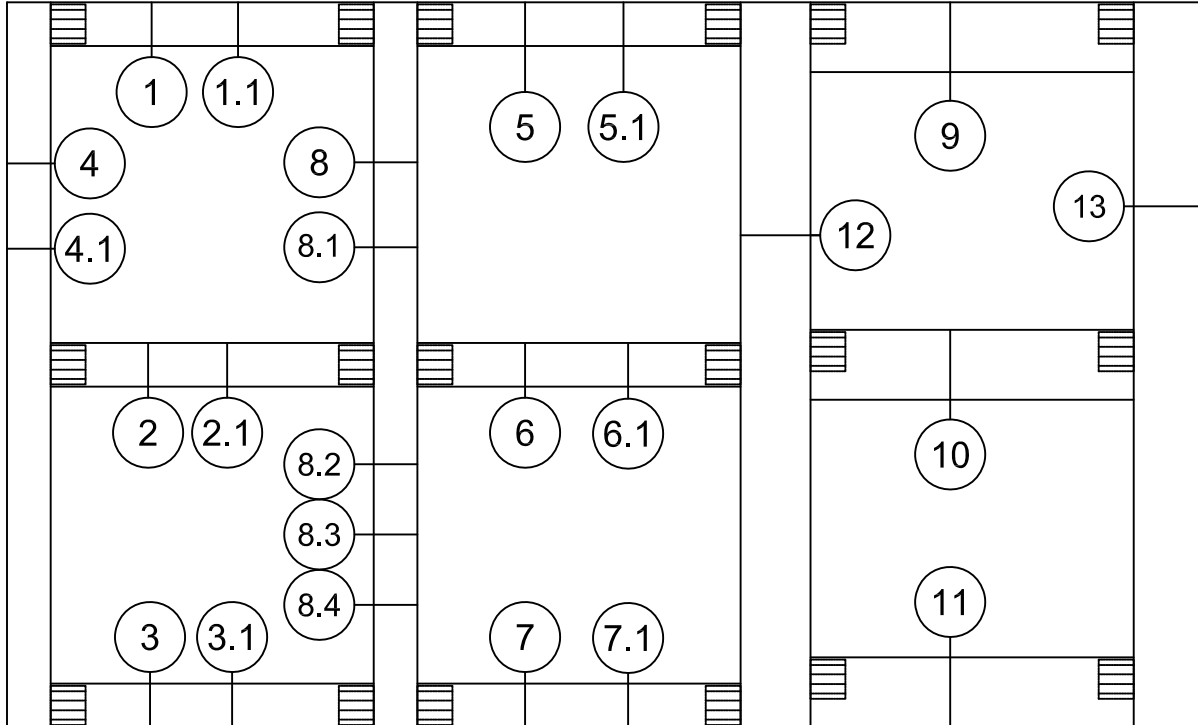

1

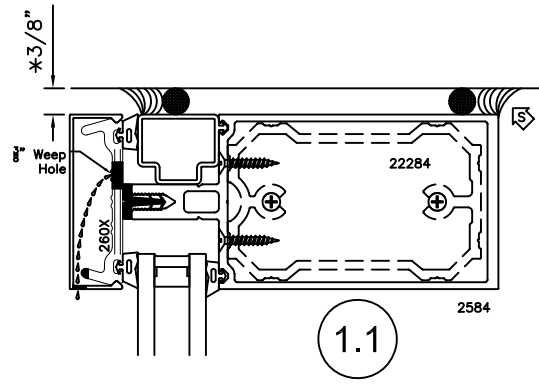

1.1

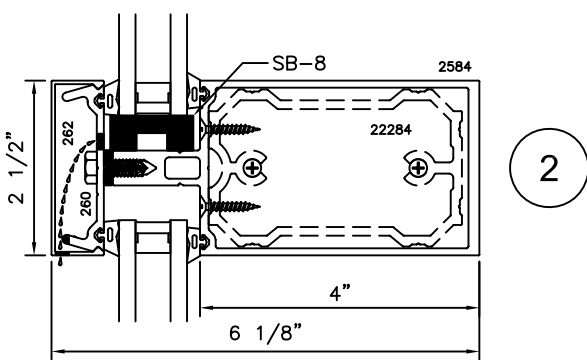

2

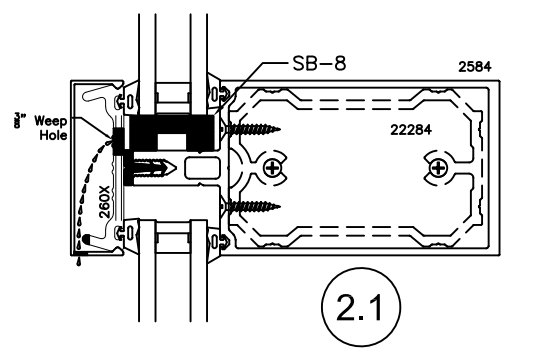

2.1



2-1/2" X 6-1/8" (4" B. M.) 250 C.W. EXTERIOR GLAZED CURTAIN WALL STANDARD / OPTIONAL DETAILS

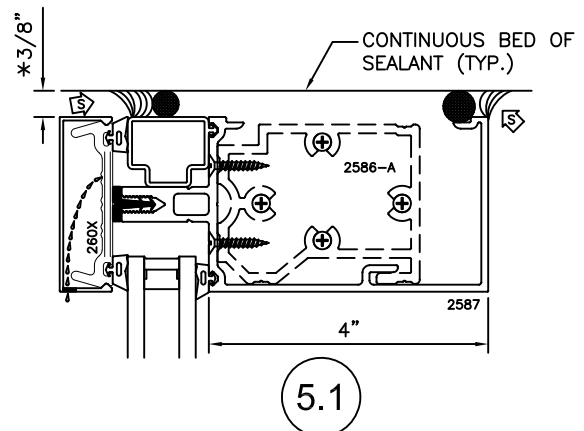
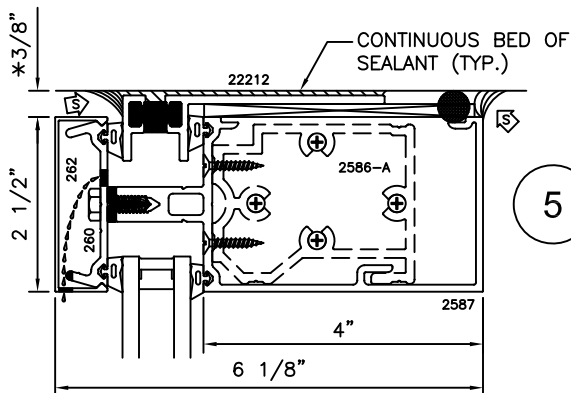
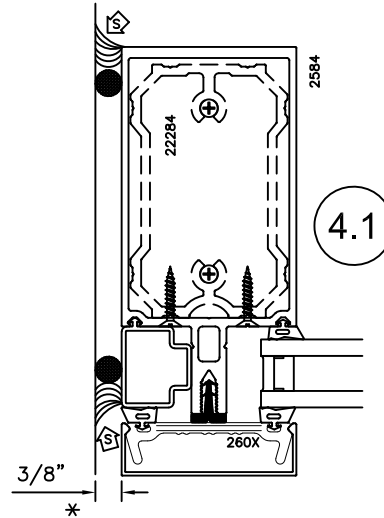
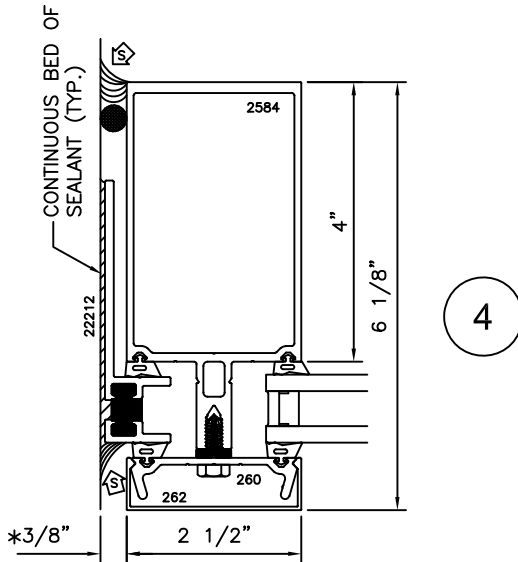
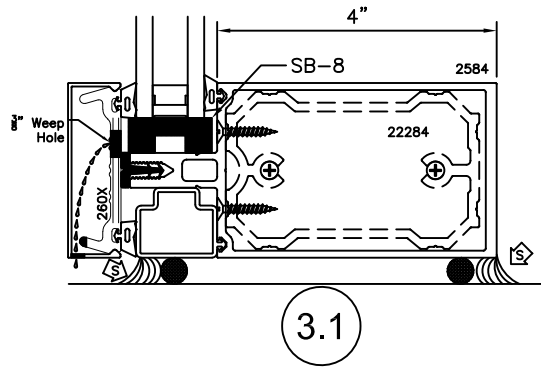
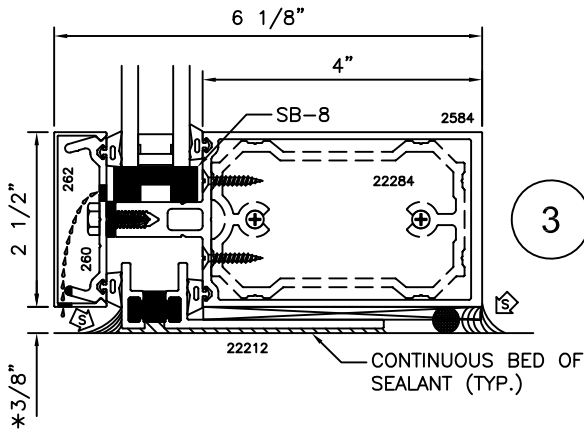



2-1/2" X 6-1/8" (4" B. M.) 250 C.W. EXTERIOR GLAZED CURTAIN WALL STANDARD / OPTIONAL DETAILS

* MINIMUM RECOMMENDED FOR THERMAL ISOLATION.
INCREASE AS REQUIRED TO COMPLY WITH SEALANT
MANUFACTURERS' INSTRUCTIONS

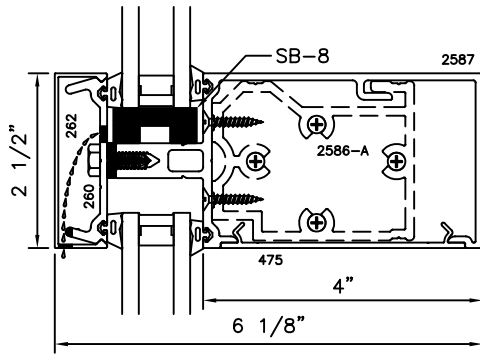

6

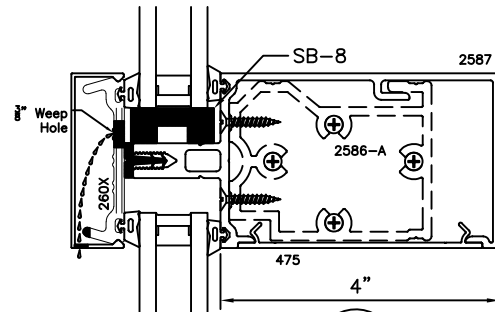

6.1

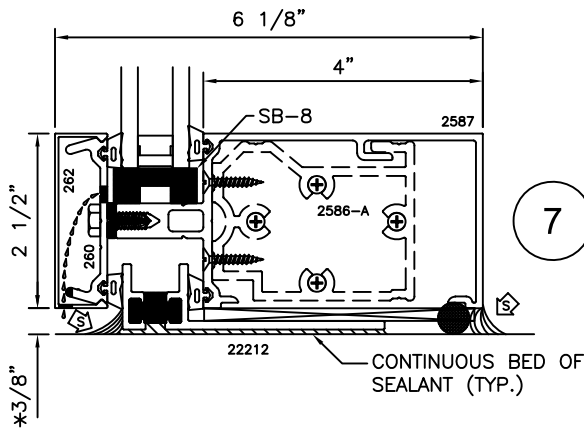

7

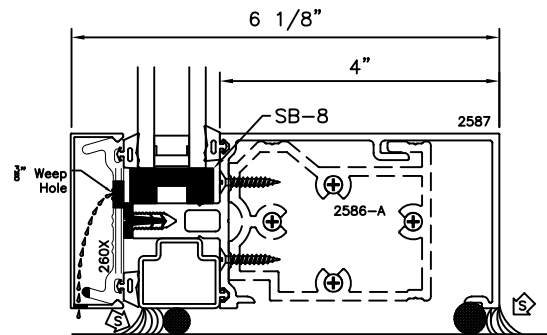

7.1

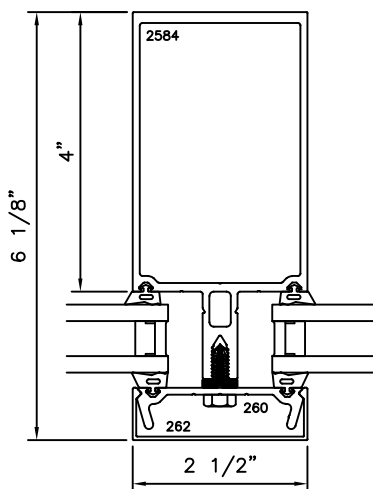

8

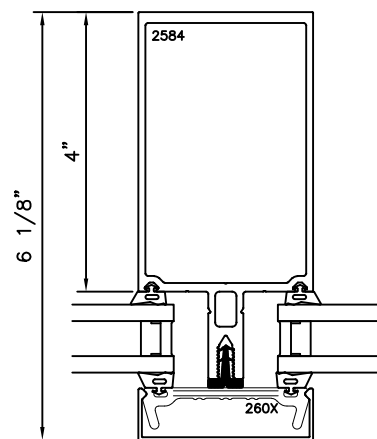

8.1



2-1/2" X 6-1/8" (4" B. M.) 250 C.W. EXTERIOR GLAZED CURTAIN WALL STANDARD / OPTIONAL DETAILS

* MINIMUM RECOMMENDED FOR THERMAL ISOLATION.
INCREASE AS REQUIRED TO COMPLY WITH SEALANT
MANUFACTURERS' INSTRUCTIONS

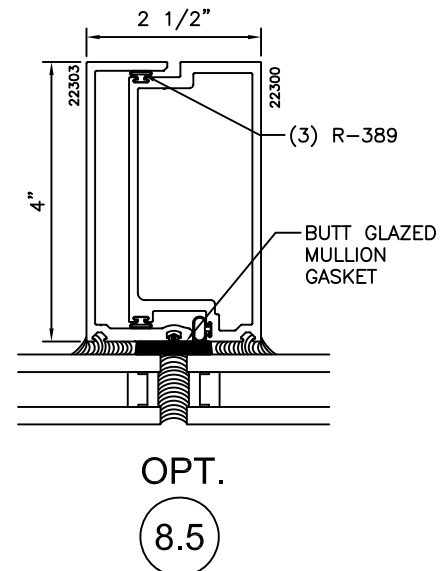
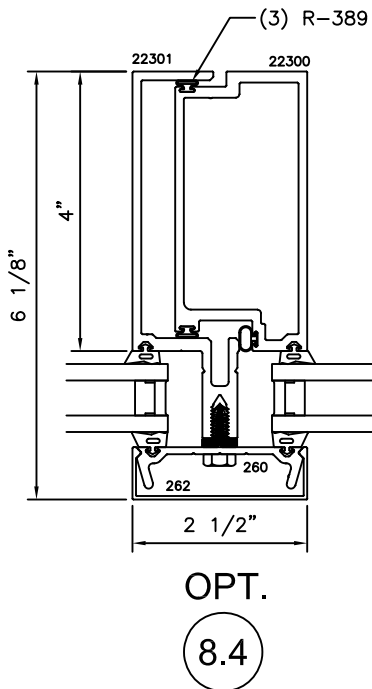
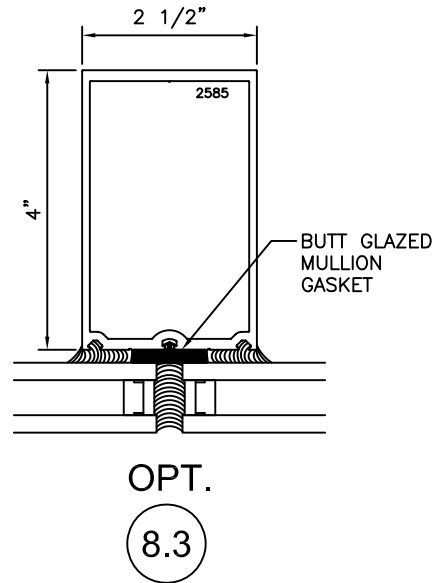
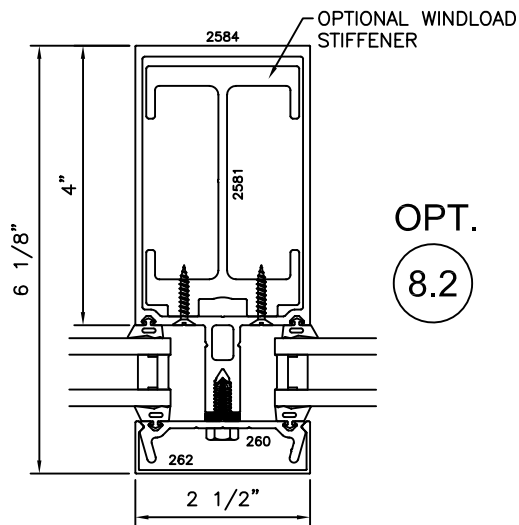



2-1/2" X 6-1/8" (4" B. M.) 250 C.W. EXTERIOR GLAZED CURTAIN WALL STANDARD / OPTIONAL DETAILS

* MINIMUM RECOMMENDED FOR THERMAL ISOLATION.
INCREASE AS REQUIRED TO COMPLY WITH SEALANT
MANUFACTURERS' INSTRUCTIONS

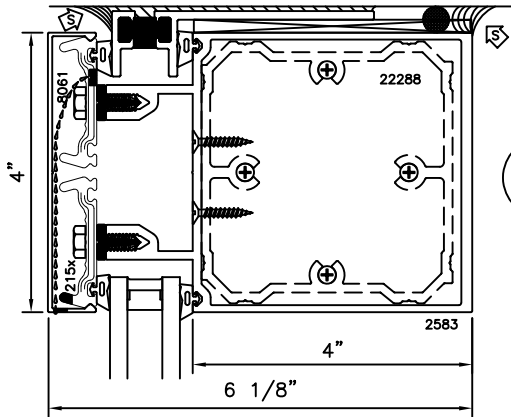

9

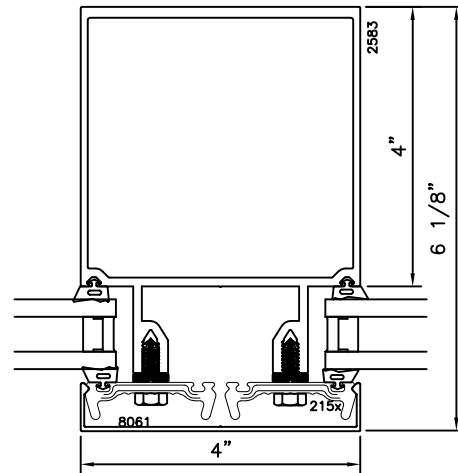

12

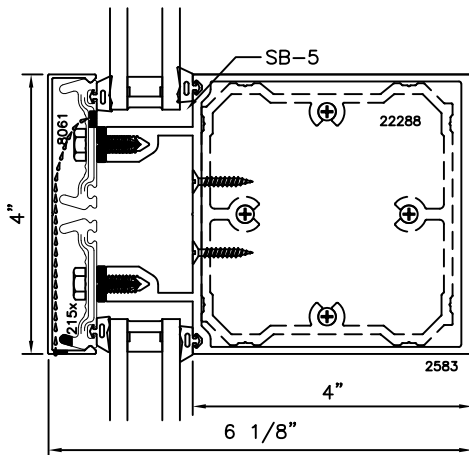

10

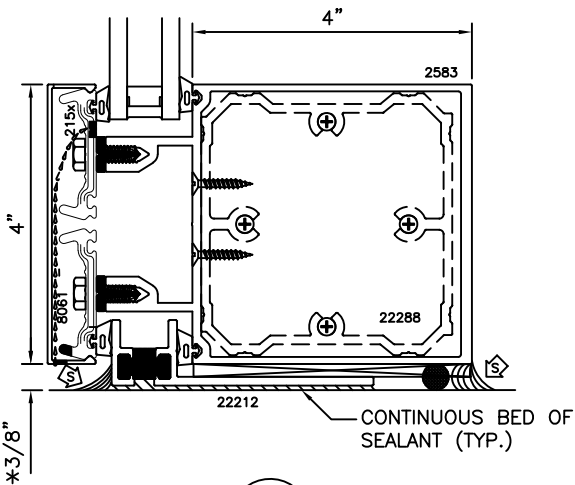

11

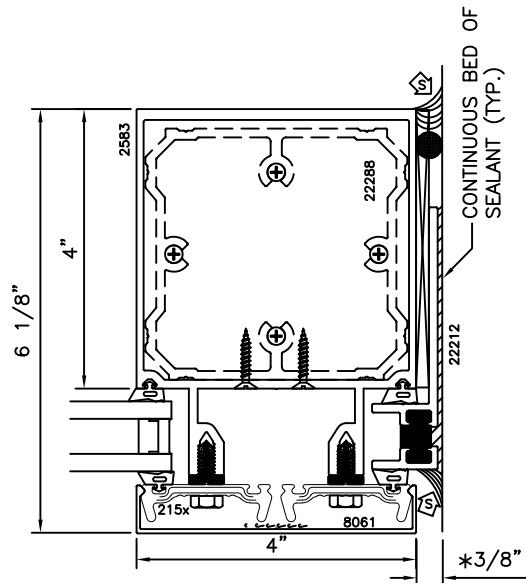

13



2-1/2" X 6-1/8" (4" B. M.) 250 C.W. EXTERIOR GLAZED CURTAIN WALL F & T ANCHOR DETAILS

* MINIMUM RECOMMENDED FOR THERMAL ISOLATION.
INCREASE AS REQUIRED TO COMPLY WITH SEALANT
MANUFACTURERS' INSTRUCTIONS

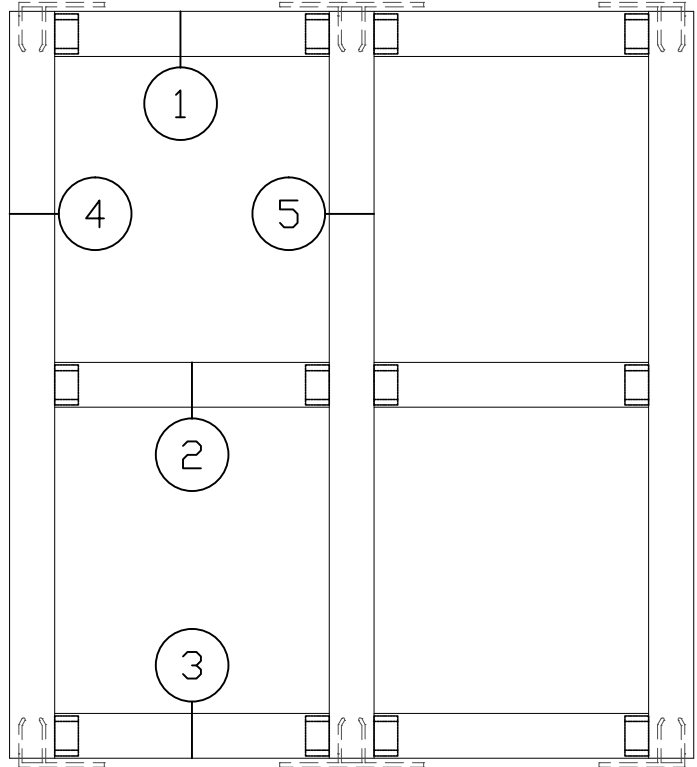
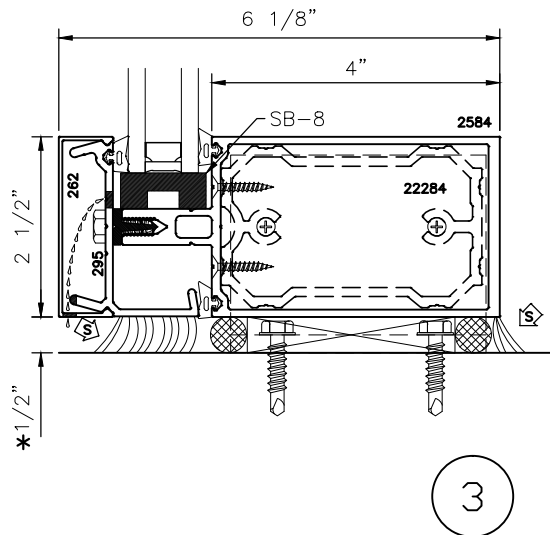
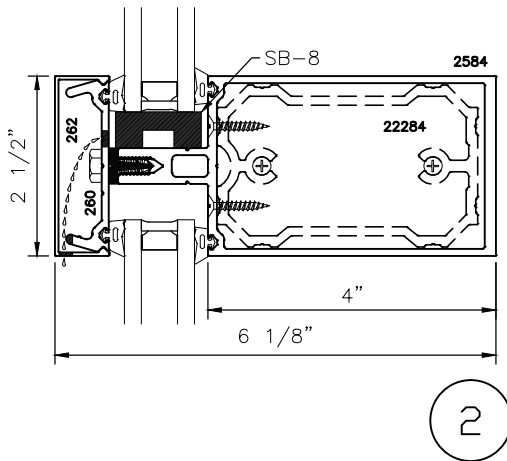
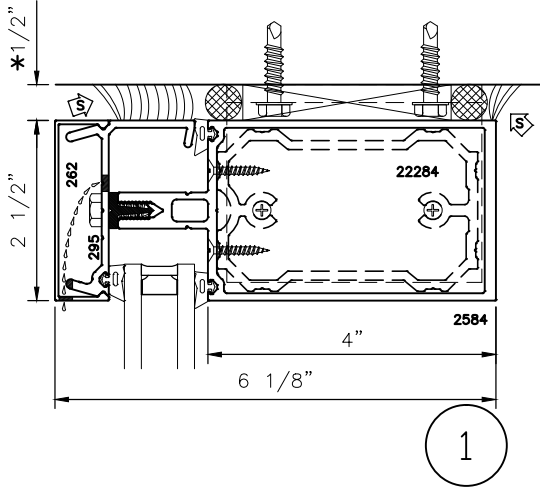

HEX HEAD SS BOLTS
ANCHOR FASTENERS (TYP.).
CONTINUOUS BED OF SEALANT
UNDER "F" & "T" ANCHORS

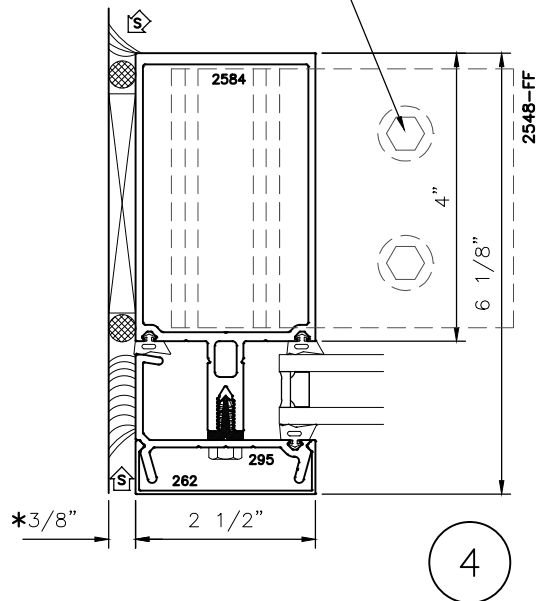



2-1/2" X 6-1/8" (4" B. M.) 250 C.W. EXTERIOR GLAZED CURTAIN WALL F & T ANCHOR DETAILS

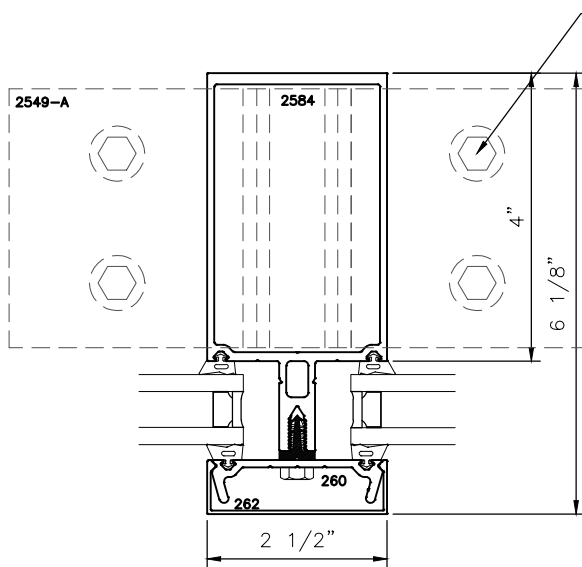

5

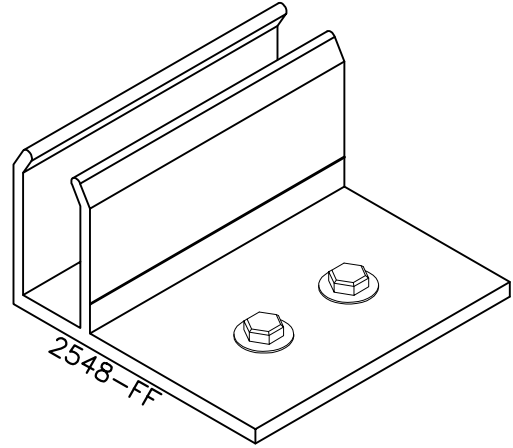

BOTTOM F-ANCHOR

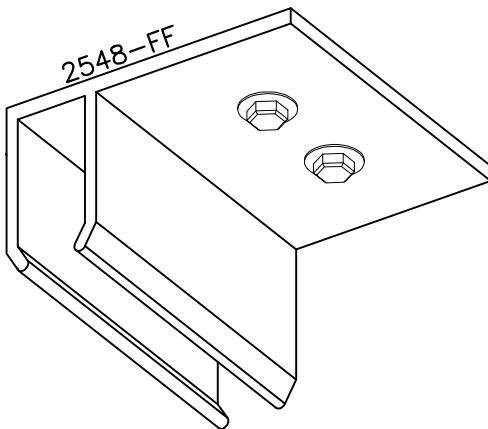

TOP F-ANCHOR

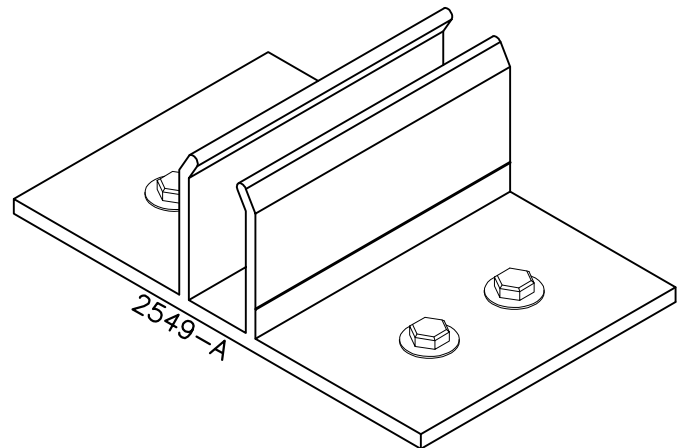

BOTTOM T-ANCHOR

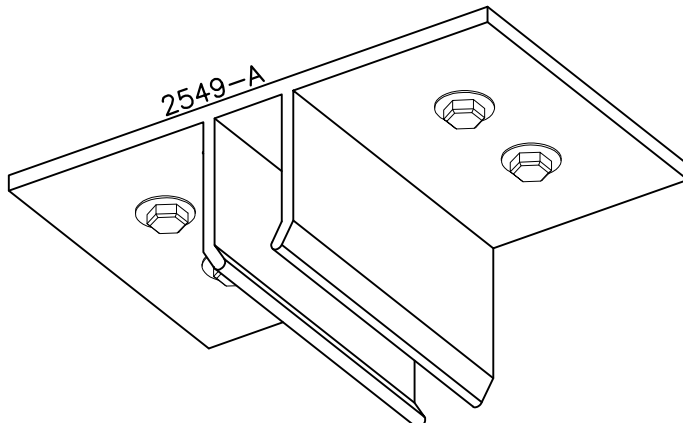

TOP T-ANCHOR



MANKO

2-1/2" X 6-1/8" (4" B. M.)
250 C.W. EXTERIOR GLAZED CURTAIN WALL
CORNER MULLION DETAILS

CAPTURED 90° CORNER MULLION

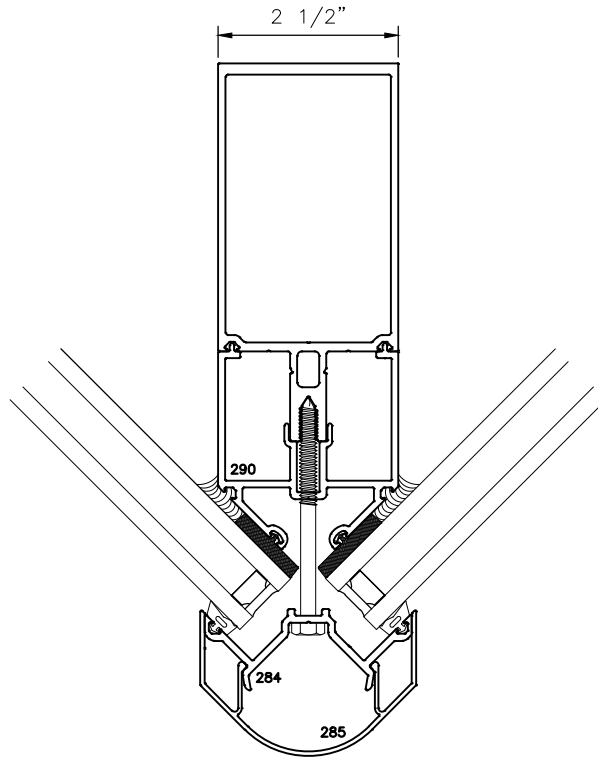

STRUCTURAL SILICONE GLAZED(SSG)
90° CORNER MULLION

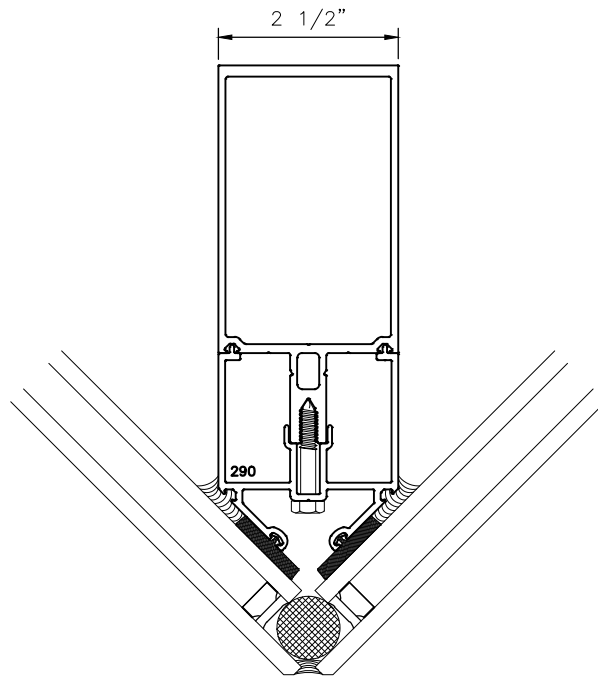

PART # 2584 SHOWN. SIMILAR
THROUGHOUT SERIES.