



MANKO

WINDOW SYSTEMS INC.

450 Series Accessory Details

Table of Contents

Inside Glaze.....	1-2
Receptors.....	3-4
Splayed Mullion.....	5
Sub-Sills.....	6
Grid Profiles.....	7



MANKO

450

1 3/4" X 4 1/2" NON-THERMAL STOREFRONT INSIDE GLAZE DETAILS

* MINIMUM RECOMMENDED FOR THERMAL ISOLATION.
INCREASE AS REQUIRED TO COMPLY WITH SEALANT
MANUFACTURERS' INSTRUCTIONS

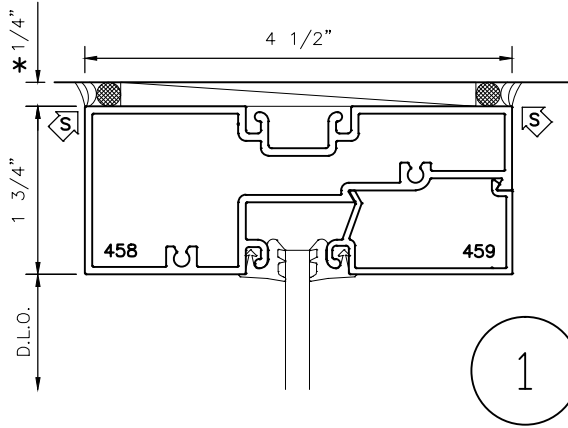

1

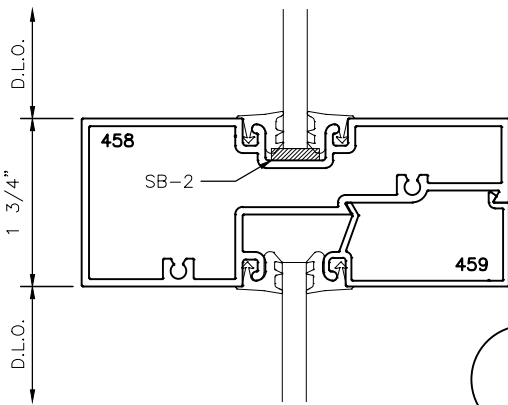

2

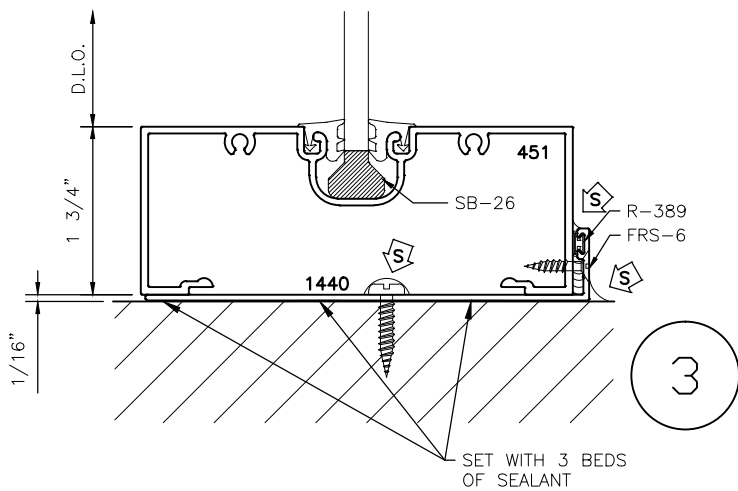

3

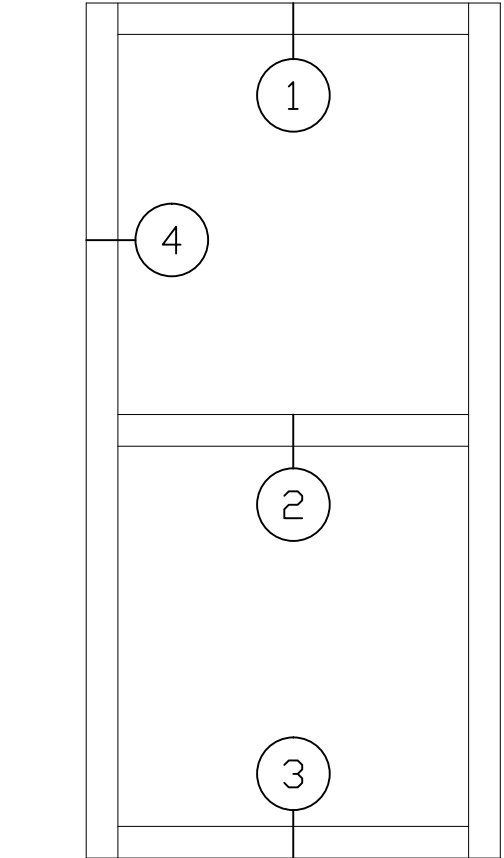

4

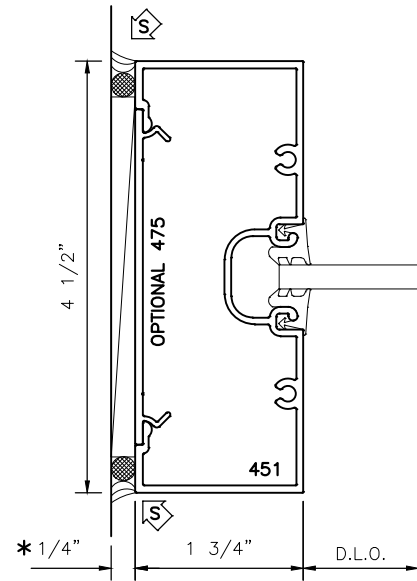



MANKO

450

2" X 4 1/2" NON-THERMAL STOREFRONT INSIDE GLAZE DETAILS

* MINIMUM RECOMMENDED FOR THERMAL ISOLATION. INCREASE AS REQUIRED TO COMPLY WITH SEALANT MANUFACTURERS' INSTRUCTIONS

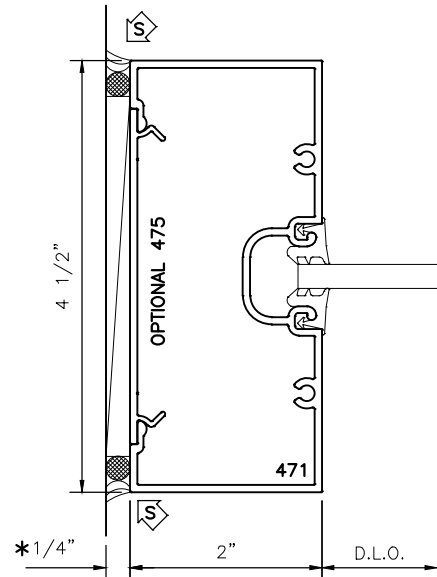
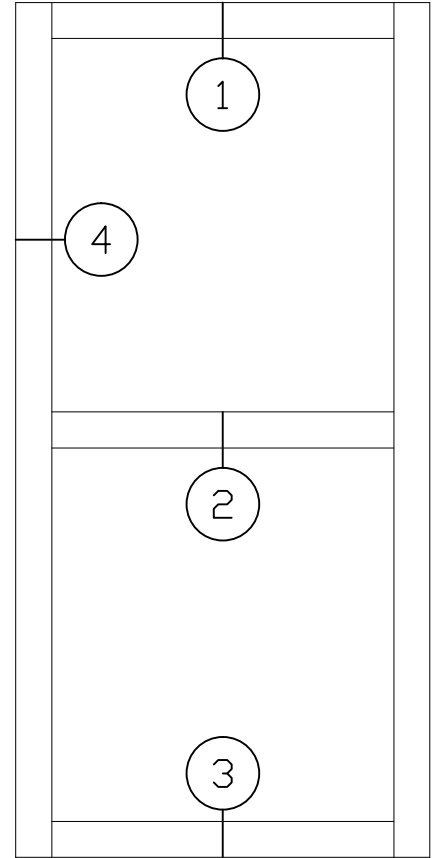
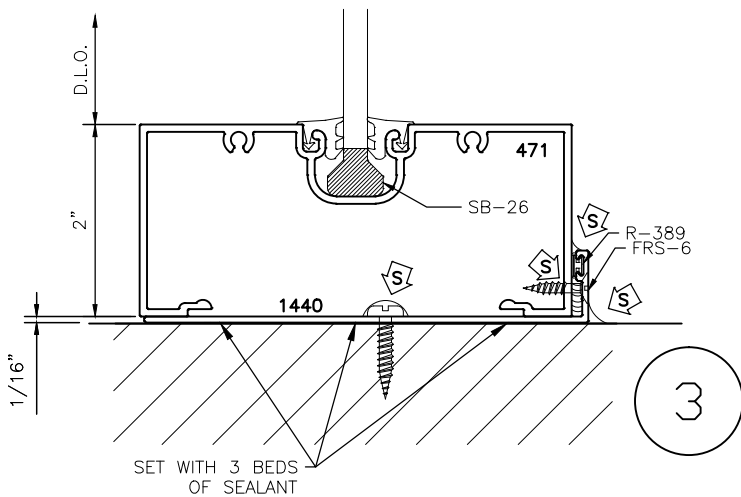
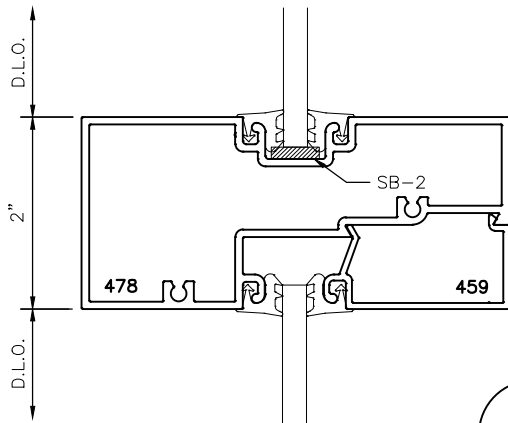
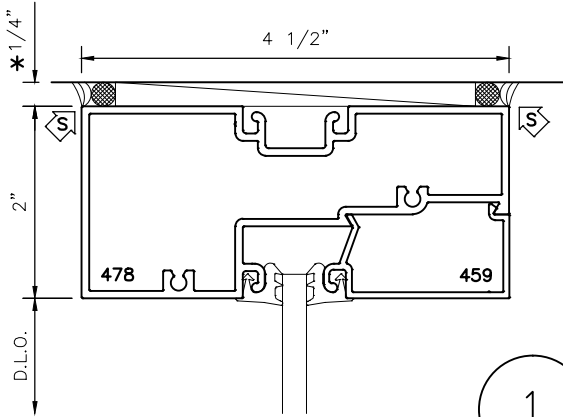



MANKO

450

1 3/4" X 4 1/2" NON-THERMAL STOREFRONT RECEPTOR DETAILS

* MINIMUM RECOMMENDED FOR THERMAL ISOLATION. INCREASE AS REQUIRED TO COMPLY WITH SEALANT MANUFACTURERS' INSTRUCTIONS

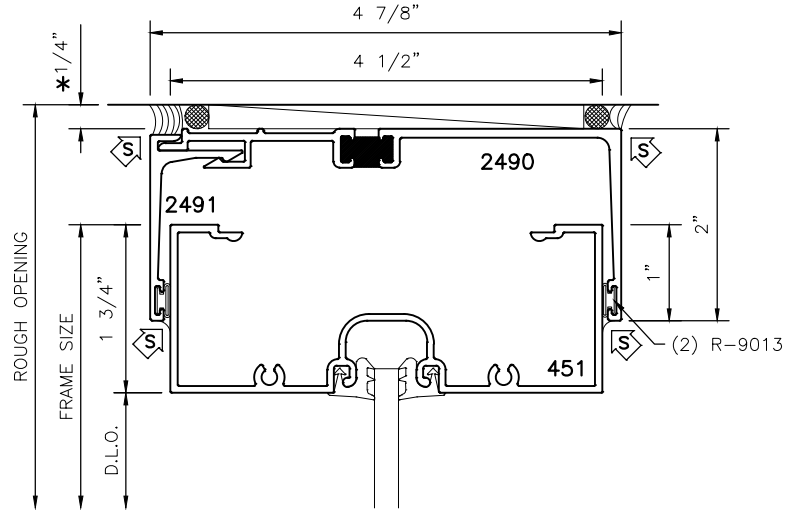

HEAD

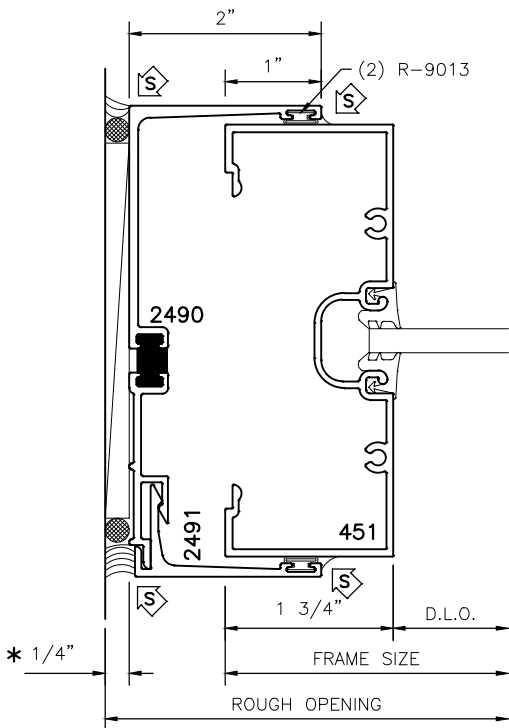

LEFT JAMB

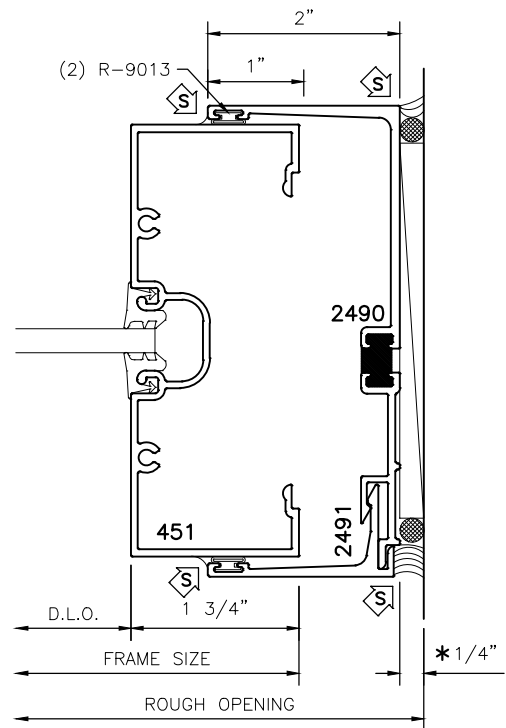

RIGHT JAMB



MANKO

450

2" X 4 1/2" NON-THERMAL STOREFRONT RECEPTOR DETAILS

* MINIMUM RECOMMENDED FOR THERMAL ISOLATION. INCREASE AS REQUIRED TO COMPLY WITH SEALANT MANUFACTURERS' INSTRUCTIONS

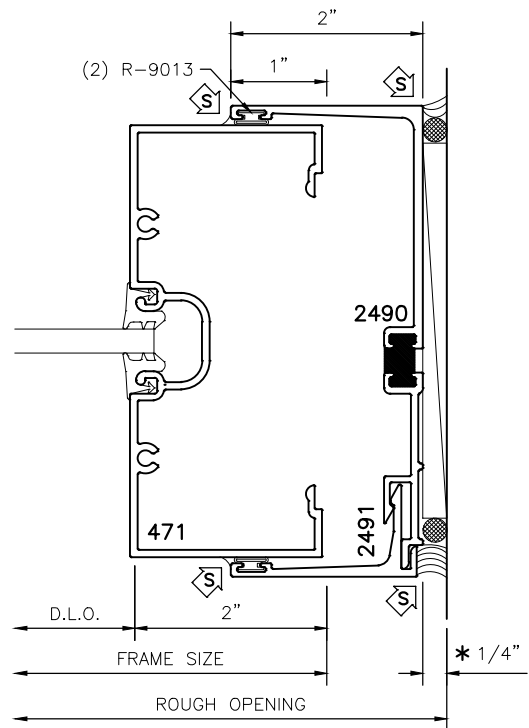
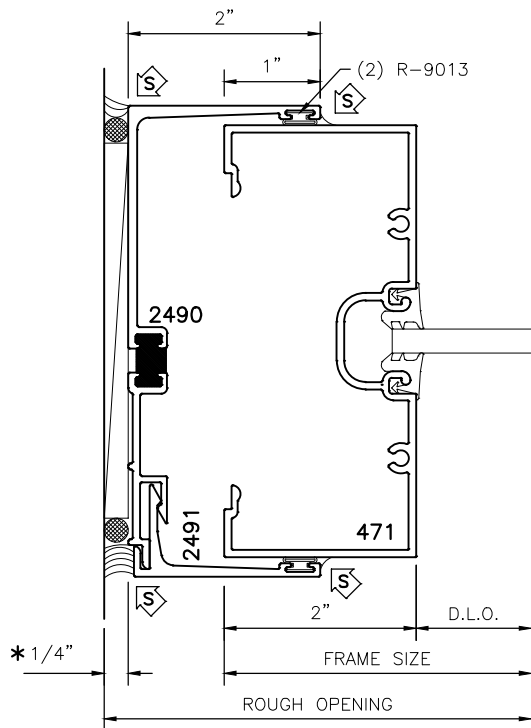
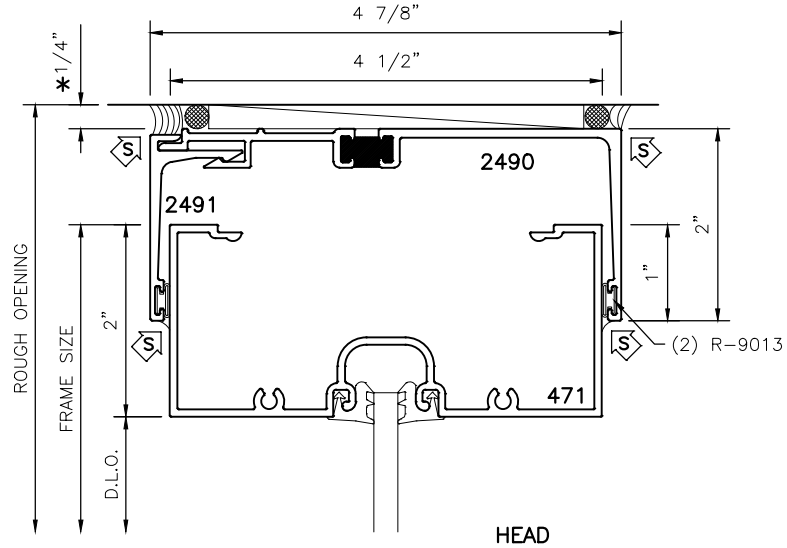



MANKO

450

**4 1/2" NON-THERMAL
STOREFRONT
SPLAYED MULLION DETAIL**

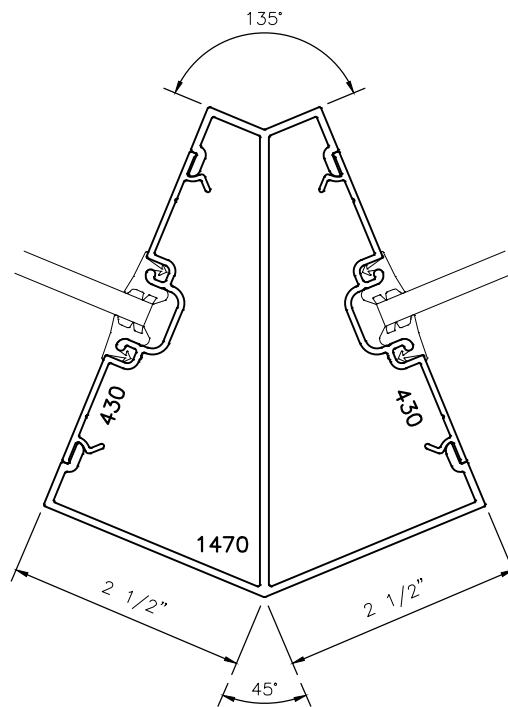



MANKO

450

4 1/2" NON-THERMAL STOREFRONT SUB-SILL DETAIL

*MINIMUM RECOMMENDED FOR THERMAL ISOLATION.
INCREASE AS REQUIRED TO COMPLY WITH SEALANT
MANUFACTURERS' INSTRUCTIONS

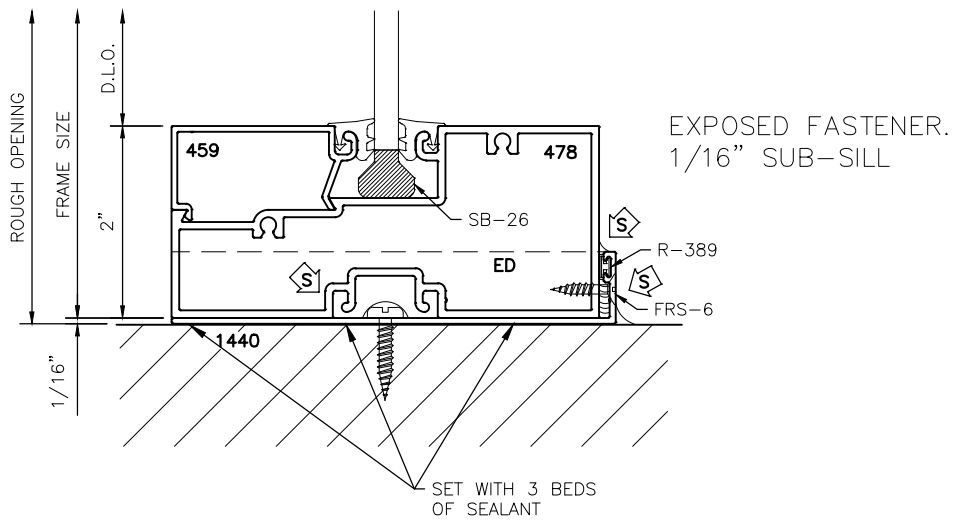
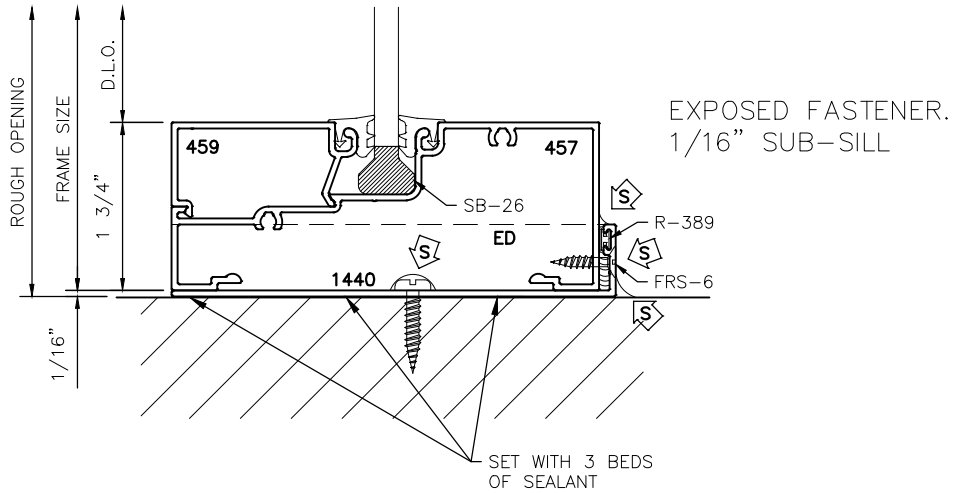



GRID PROFILES

Storefront & Curtain Wall

2471

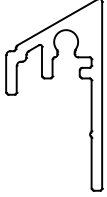

2470

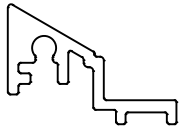

824

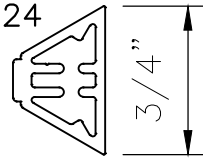

890

